

Date of Issue: April 2018

Affected Publication: API 570, *Piping Inspection Code: In-service Inspection, Rating, Repair, and Alteration of Piping Systems*, Fourth Edition, February 2016

Errata 1

Page 40: Section 5.11.4, second paragraph, shall read:

To minimize the risk of brittle fracture during a pressure test, the metal temperature should be maintained at least 30 °F (17 °C) above the MDMT for piping that is more than 2 in. (5 cm) thick, and 10 °F (6 °C) above the MDMT for piping that have a thickness of 2 in. (5 cm) or less. The test temperature need not exceed 120 °F (50 °C) unless there is information on the brittle characteristics of the piping construction material indicating a higher test temperature is needed.

Page 61: Section 7.13, second paragraph, shall read:

Piping or pressure-relieving devices that are operated beyond the due date without a valid deferral in accordance with these requirements are not permitted by this code. Deferrals should be the occasional exception, not a frequent occurrence. All deferrals shall be documented. Piping or pressure-relieving devices that were granted a deferral can be operated to the new due date without being considered overdue for the deferred inspections, tests, or examinations.

Page 61: Section 7.13.1 c), shall read:

- c) A review of the current operating conditions, as well as the piping or pressure-relieving device history, has been completed with results that support a short-term/one-time deferral.

Page 62: Section 7.13.2 a), last two sub-bullets, shall read:

- disposition(s) of any previous requests for deferral on the same piping or pressure-relieving device;
- historical conditions/findings for piping or pressure-relieving devices in similar service, if available.

Page 62: Section 7.13.2 d), shall read:

- d) Obtain the consent and approval of appropriate piping personnel including the inspector representing, or employed by the owner-user and appropriate operations management representative(s).

Piping Inspection Code: In-service Inspection, Rating, Repair, and Alteration of Piping Systems

API 570
FOURTH EDITION, FEBRUARY 2016

ADDENDUM 1, MAY 2017
ADDENDUM 2, MARCH 2018
ERRATA 1, APRIL 2018



AMERICAN PETROLEUM INSTITUTE

Special Notes

API publications necessarily address problems of a general nature. With respect to particular circumstances, local, state, and federal laws and regulations should be reviewed.

Neither API nor any of API's employees, subcontractors, consultants, committees, or other assignees make any warranty or representation, either express or implied, with respect to the accuracy, completeness, or usefulness of the information contained herein, or assume any liability or responsibility for any use, or the results of such use, of any information or process disclosed in this publication. Neither API nor any of API's employees, subcontractors, consultants, or other assignees represent that use of this publication would not infringe upon privately owned rights.

API publications may be used by anyone desiring to do so. Every effort has been made by the Institute to assure the accuracy and reliability of the data contained in them; however, the Institute makes no representation, warranty, or guarantee in connection with this publication and hereby expressly disclaims any liability or responsibility for loss or damage resulting from its use or for the violation of any authorities having jurisdiction with which this publication may conflict.

API publications are published to facilitate the broad availability of proven, sound engineering and operating practices. These publications are not intended to obviate the need for applying sound engineering judgment regarding when and where these publications should be utilized. The formulation and publication of API publications is not intended in any way to inhibit anyone from using any other practices.

Any manufacturer marking equipment or materials in conformance with the marking requirements of an API standard is solely responsible for complying with all the applicable requirements of that standard. API does not represent, warrant, or guarantee that such products do in fact conform to the applicable API standard.

Classified areas may vary depending on the location, conditions, equipment, and substances involved in any given situation. Users of this Standard should consult with the appropriate authorities having jurisdiction.

Users of this Standard should not rely exclusively on the information contained in this document. Sound business, scientific, engineering, and safety judgment should be used in employing the information contained herein.

API is not undertaking to meet the duties of employers, manufacturers, or suppliers to warn and properly train and equip their employees, and others exposed, concerning health and safety risks and precautions, nor undertaking their obligations to comply with authorities having jurisdiction.

Information concerning safety and health risks and proper precautions with respect to particular materials and conditions should be obtained from the employer, the manufacturer or supplier of that material, or the material safety data sheet.

All rights reserved. No part of this work may be reproduced, translated, stored in a retrieval system, or transmitted by any means, electronic, mechanical, photocopying, recording, or otherwise, without prior written permission from the publisher. Contact the Publisher, API Publishing Services, 1220 L Street, NW, Washington, DC 20005.

Copyright © 2016 American Petroleum Institute

Foreword

Nothing contained in any API publication is to be construed as granting any right, by implication or otherwise, for the manufacture, sale, or use of any method, apparatus, or product covered by letters patent. Neither should anything contained in the publication be construed as insuring anyone against liability for infringement of letters patent.

Shall: As used in a standard, “shall” denotes a minimum requirement in order to conform to the specification.

Should: As used in a standard, “should” denotes a recommendation or that which is advised but not required in order to conform to the specification.

This document was produced under API standardization procedures that ensure appropriate notification and participation in the developmental process and is designated as an API standard. Questions concerning the interpretation of the content of this publication or comments and questions concerning the procedures under which this publication was developed should be directed in writing to the Director of Standards, American Petroleum Institute, 1220 L Street, NW, Washington, DC 20005. Requests for permission to reproduce or translate all or any part of the material published herein should also be addressed to the director.

Generally, API standards are reviewed and revised, reaffirmed, or withdrawn at least every five years. A one-time extension of up to two years may be added to this review cycle. Status of the publication can be ascertained from the API Standards Department, telephone (202) 682-8000. A catalog of API publications and materials is published annually by API, 1220 L Street, NW, Washington, DC 20005.

Suggested revisions are invited and should be submitted to the Standards Department, API, 1220 L Street, NW, Washington, DC 20005, standards@api.org.

Contents

Page

1	Scope	1
1.1	General Application	1
1.2	Specific Applications	1
1.3	Fitness-For-Service (FFS) and Risk-Based Inspection (RBI)	2
2	Normative References	2
3	Terms, Definitions, Acronyms, and Abbreviations	4
3.1	Terms and Definitions	4
3.2	Acronyms and Abbreviations	16
4	Owner/User Inspection Organization	18
4.1	General	18
4.2	Authorized Piping Inspector Qualification and Certification	18
4.3	Responsibilities	18
5	Inspection, Examination, and Pressure Testing Practices	22
5.1	Inspection Plans	22
5.2	RBI	24
5.3	Preparation for Inspection	25
5.4	Inspection for Types and Locations of Damage Modes of Deterioration and Failure	26
5.5	General Types of Inspection and Surveillance	28
5.6	CMLs	31
5.7	Condition Monitoring Methods	33
5.8	Corrosion Under Insulation Inspection	36
5.9	Mixing Point Inspection	36
5.10	Injection Point Inspection	37
5.11	Pressure Testing of Piping Systems	38
5.12	Material Verification and Traceability	40
5.13	Inspection of Valves	41
5.14	In-service Inspection of Welds	42
5.15	Inspection of Flanged Joints	43
6	Interval/Frequency and Extent of Inspection	43
6.1	General	43
6.2	Inspection During Installation and Service Changes	44
6.3	Piping Inspection Planning	44
6.4	Extent of Visual External and CUI Inspections	48
6.5	Extent of Thickness Measurement Inspection and Data Analysis	49
6.6	Extent of Inspections on Small-bore Piping, Deadlegs, Auxiliary Piping, and Threaded Connections	51
6.7	Inspection and Maintenance of Pressure-relieving Devices (PRDs)	53
7	Inspection Data Evaluation, Analysis, and Recording	54
7.1	Corrosion Rate Determination	54
7.2	Remaining Life Calculations	55
7.3	Newly Installed Piping Systems or Changes in Service	55
7.4	Existing and Replacement Piping	56
7.5	MAWP Determination	56
7.6	Required Thickness Determination	56
7.7	Assessment of Inspection Findings	57
7.8	Piping Stress Analysis	57
7.9	Reporting and Records for Piping System Inspection	58

Contents

	Page
7.10 Inspection Recommendations for Repair or Replacement	60
7.11 Inspection Records for External Inspections	61
7.12 Piping Failure and Leak Reports	61
7.13 Deferral of Inspections, Examinations, and Tests	61
8 Repairs, Alterations, and Rerating of Piping Systems	62
8.1 Repairs and Alterations	62
8.2 Welding and Hot Tapping	65
8.3 Re-rating	70
9 Inspection of Buried Piping	71
9.1 General	71
9.2 Above-grade Visual Surveillance	71
9.3 Close-interval Potential Survey	71
9.4 Pipe Coating Holiday Survey	72
9.5 Soil Resistivity	72
9.6 Cathodic Protection Monitoring	72
9.7 Inspection Methods	72
9.8 Frequency and Extent of Inspection	73
9.9 Repairs to Buried Piping Systems	74
9.10 Records	75
Annex A (informative) Inspector Certification	76
Annex B (informative) Requests for Interpretations	77
Annex C (informative) Examples of Repairs	78
Annex D (informative) Two Examples of the Calculation of MAWP Illustrating the Use of the Corrosion Half-life Concept	80
Bibliography	81
Figures	
1 Typical Injection Point Piping Circuit	38
C.1 Encirclement Repair Sleeve	78
C.2 Small Repair Patches	79
Tables	
1 Recommended Maximum Inspection Intervals	45
2 Recommended Extent of CUI Inspection Following Visual Inspection for Susceptible Piping	48
3 Welding Methods as Alternatives to Post-weld Heat Treatment Qualification Thickness for Test Plates and Repair Grooves	68
4 Frequency of Inspection for Buried Piping Without Effective Cathodic Protection	74

Piping Inspection Code: In-service Inspection, Rating, Repair, and Alteration of Piping Systems

1 Scope

1.1 General Application

1.1.1 Coverage

API 570 covers inspection, rating, repair, and alteration procedures for metallic and fiberglass-reinforced plastic (FRP) piping systems and their associated pressure relieving devices that have been placed in service. This inspection Code applies to all hydrocarbon and chemical process piping covered in 1.2.1 that have been placed in service unless specifically designated as optional per 1.2.2. This publication does not cover inspection of specialty equipment including instrumentation, exchanger tubes and control valves. However, this piping Code could be used by owner/users in other industries and other services at their discretion.

Process piping systems that have been retired from service and abandoned in place are no longer covered by this “in service inspection” Code. However abandoned in place piping may still need some amount of inspection and/or risk mitigation to assure that it does not become a process safety hazard because of continuing deterioration. Process piping systems that are temporarily out of service but have been mothballed (preserved for potential future use) are still covered by this Code.

1.1.2 Intent

The intent of this Code is to specify the in-service inspection and condition-monitoring program as well as repair guidance that is needed to determine and maintain the on-going integrity of piping systems. That program should provide reasonably accurate and timely assessments to determine if any changes in the condition of piping could possibly compromise continued safe operation. It is also the intent of this Code that owner/users shall respond to any inspection results that require corrective actions to assure the continued integrity of piping consistent with appropriate risk analysis. API 570 is intended for use by organizations that maintain or have access to an authorized inspection agency, a repair organization, and technically qualified piping engineers, inspectors, and examiners, all as defined in Section 3.

1.1.3 Limitations

API 570 shall not be used as a substitute for the original construction requirements governing a piping system before it is placed in-service; nor shall it be used in conflict with any prevailing regulatory requirements. If the requirements of this Code are more stringent than the regulatory requirements, then the requirements of this Code shall govern.

1.2 Specific Applications

The term non-metallics has a broad definition but in this Code refers to the fiber reinforced plastic groups encompassed by the generic acronyms FRP (fiberglass-reinforced plastic) and GRP (glass-reinforced plastic). The extruded, generally homogenous non-metallics, such as high and low-density polyethylene are not specifically covered by this Code. Refer to API 574 and MTI 129 for guidance on degradation and inspection issues associated with FRP piping.

1.2.1 Included Fluid Services

Except as provided in 1.2.2, API 570 applies to piping systems for process fluids, hydrocarbons, and similar flammable or toxic fluid services, such as the following:

- a) raw, intermediate, and finished petroleum and chemical products;
- b) catalyst lines;
- c) hydrogen, natural gas, fuel gas, and flare systems;
- d) sour water and hazardous waste streams;
- e) hazardous fluid services;
- f) cryogenic fluids such as: liquid N₂, H₂, O₂, and air;
- g) high-pressure gases greater than 150 psig such as: gaseous He, H₂, O₂, and N₂.

1.2.2 Optional Piping Systems and Fluid Services

The fluid services and classes of piping systems listed below are optional with regard to the requirements of API 570:

- a) hazardous fluid services below designated threshold limits, as defined by jurisdictional regulations;
- b) water (including fire protection systems), steam, steam-condensate, boiler feed water, and Category D fluid services as defined in ASME B31.3;
- c) other classes of piping that are exempted from the applicable process piping code.

1.3 Fitness-For-Service (FFS) and Risk-Based Inspection (RBI)

This inspection Code recognizes Fitness-For-Service concepts for evaluating in-service damage of pressure containing piping components. API 579-1/ASME FFS-1, *Fitness-For-Service* provides detailed FFS assessment procedures for specific types of damage that are referenced in this Code. This inspection Code also recognizes RBI concepts for determining inspection intervals or due dates and strategies. API 580 provides the basic minimum and recommended elements for developing, implementing, and maintaining a risk-based inspection (RBI) program for fixed equipment, including piping. API 581 provides a set of methodologies for assessing risk (both POF and COF) and for developing inspection plans.

2 Normative References

The following referenced documents are indispensable for the application of this document. For dated references, only the edition cited applies. For undated references, the latest edition of the referenced document (including any amendments) applies.

API Standard 510, *Pressure Vessel Inspection Code: Maintenance Inspection, Rating, Repair, and Alteration*

API Standard 530, *Calculation of Heater Tube Thicknesses in Petroleum Refineries*

API Recommended Practice 571, *Damage Mechanisms Affecting Fixed Equipment in the Refining Industry*

API Recommended Practice 572, *Inspection Practices for Pressure Vessels*

API Recommended Practice 574, *Inspection Practices for Piping System Components*

API Recommended Practice 576, *Inspection of Pressure-relieving Devices*

API Recommended Practice 577, *Welding Inspection and Metallurgy*

API Recommended Practice 578, *Material Verification Program for New and Existing Piping Systems*

API Standard 579-1/ASME FFS-1, *Fitness-For-Service*

API Recommended Practice 580, *Risk-based Inspection*

API Recommended Practice 583, *Corrosion Under Insulation*

API Recommended Practice 584, *Integrity Operating Windows*

API Standard 598, *Valve Inspection and Testing*

API Recommended Practice 939-C, *Guidelines for Avoiding Sulfidation (Sulfidic) Corrosion Failures in Oil Refineries*

API Recommended Practice 941, *Steels for Hydrogen Service at Elevated Temperatures and Pressures in Petroleum Refineries and Petrochemical Plants*

API Publication 2201, *Safe Hot Tapping Practices in the Petroleum and Petrochemical Industries*

ASME B16.34 ¹, *Valves—Flanged, Threaded, and Welding End*

ASME B31.3, *Process Piping*

ASME Boiler and Pressure Vessel Code (BPVC), Section V, *Nondestructive Examination*

ASME BPVC, Section IX, *Welding and Brazing Qualifications*

ASME PCC-1, *Guidelines for Pressure Boundary Bolted Flange Joint Assembly*

ASME PCC-2, *Repair of Pressure Equipment and Piping*

ASTM G57 ², *Method for Field Measurement of Soil Resistivity Using the Wenner Four-Electrode Method*

NACE RP 0472 ³, *Methods and Controls to Prevent In-Service Environmental Cracking of Carbon Steel Weldments in Corrosive Petroleum Refining Environments*

NACE MR 0103, *Materials Resistant to Sulfide Stress Cracking in Corrosive Petroleum Refining Environments*

NACE SP 0102, *In-Line Inspection of Pipelines*

NACE RP 0502, *Pipeline External Corrosion Direct Assessment. Methodology*

NFPA 704 ⁴, *Standard System for the Identification of the Hazards of Materials for Emergency Response*

¹ASME International, 3 Park Avenue, New York, New York 10016-5990, www.asme.org.

²ASTM International, 100 Barr Harbor Drive, West Conshohocken, Pennsylvania 19428, www.astm.org.

³NACE International (formerly the National Association of Corrosion Engineers), 1440 South Creek Drive, Houston, Texas 77218-8340, www.nace.org

⁴NFPA National Fire Protection Association, 1 Batterymarch Park Quincy, Massachusetts USA 02169-7471

3 Terms, Definitions, Acronyms, and Abbreviations

For the purposes of this document, the following terms, definitions, acronyms, and abbreviations apply.

3.1 Terms and Definitions

3.1.1

abandoned-in-place

Piping system, circuit or contiguous sections thereof meeting all of the following: has been decommissioned with no intention for future use; has been completely de-inventoried/purged of hydrocarbon/chemicals; and is physically disconnected (e.g. air-gapped) from all energy sources and/or other piping/equipment.

3.1.2

alloy material

Any metallic material (including welding filler materials) that contains alloying elements, such as chromium, nickel, or molybdenum, which are intentionally added to enhance mechanical or physical properties and/or corrosion resistance. Alloys may be ferrous or non-ferrous based.

NOTE Carbon steels are not considered alloys, for purposes of this Code.

3.1.3

alteration

A physical change in any component that has design implications affecting the pressure containing capability or flexibility of a piping system beyond the scope of its original design. The following are not considered alterations: comparable or duplicate replacements and replacements in kind.

3.1.4

applicable code

The code, code section, or other recognized and generally accepted engineering standard or practice to which the piping system was built or which is deemed by the owner/user or the piping engineer to be most appropriate for the situation, including but not limited to the latest edition of ASME B31.3.

3.1.5

authorization

Approval/agreement to perform a specific activity (e.g. piping repair) prior to the activity being performed.

3.1.6

authorized inspection agency

Defined as any of the following:

- a) the inspection organization of the jurisdiction in which the piping system is used,
- b) the inspection organization of an insurance company that is licensed or registered to write insurance for piping systems;
- c) an owner or user of piping systems who maintains an inspection organization for activities relating only to his equipment and not for piping systems intended for sale or resale;
- d) an independent inspection organization employed by or under contract to the owner/user of piping systems that are used only by the owner/user and not for sale or resale;
- e) an independent inspection organization licensed or recognized by the jurisdiction in which the piping system is used and employed by or under contract to the owner/user.

3.1.7**authorized piping inspector**

An employee of an owner/user organization or authorized inspection agency (3.1.6) who is qualified and certified by examination under the provisions of Section 4 and Annex A and is able to perform the functions specified in API 570 where contracted or directed to do so. An NDE examiner is not required to be an authorized piping inspector. Whenever the term inspector is used in API 570, it refers to an authorized piping inspector.

3.1.8**auxiliary piping**

Instrument and machinery piping, typically small-bore secondary process piping that can be isolated from primary piping systems but is normally not isolated. Examples include flush lines, seal oil lines, analyzer lines, balance lines, buffer gas lines, drains, and vents.

3.1.9**condition monitoring locations****CMLs**

Designated areas on piping systems where periodic examinations are conducted in order to assess the condition of the piping. CMLs may contain one or more examination points and utilize multiple inspection techniques that are based on the predicted damage mechanism(s). CMLs can be a single small area on a piping system e.g. a 2 in. diameter spot or plane through a section of a pipe where examination points exist in all four quadrants of the plane.

NOTE CMLs now include, but are not limited to what were previously called TMLs.

3.1.10**construction code**

The code or standard to which the piping system was originally built (e.g. ASME B31.3).

3.1.11**contact point**

The locations at which a pipe or component rests on or against a support or other object which may increase its susceptibility to external corrosion, fretting, wear or deformation especially as a result of moisture and/or solids collecting at the interface of the pipe and supporting member.

3.1.12**corrosion allowance**

Material thickness in excess of the minimum required thickness to allow for metal loss (e.g. corrosion or erosion) during the service life of the piping component.

NOTE Corrosion allowance is not used in design strength calculations.

3.1.13**corrosion barrier**

The corrosion allowance in FRP equipment typically composed of an inner surface and an interior layer which is specified as necessary to provide the best overall resistance to chemical attack.

3.1.14**corrosion rate**

The rate of metal loss (e.g. reduction in thickness due to erosion, erosion/corrosion or the chemical reaction(s) with the environment, etc.) from internal and/or external damage mechanisms.

3.1.15**corrosion specialist**

A person acceptable to the owner/user who is knowledgeable and experienced in the specific process chemistries, degradation mechanisms, materials selection, corrosion mitigation methods, corrosion monitoring techniques, and their impact on piping systems.

3.1.16**corrosion under insulation
(CUI)**

External corrosion of carbon steel and low alloy steel piping resulting from water trapped under insulation. External chloride stress corrosion cracking (ECSCC) of austenitic and duplex stainless steel under insulation is also classified as CUI damage.

3.1.17**critical check valves**

Check valves in piping systems that have been identified as vital to process safety (see 5.13). Critical check valves are those that need to operate reliably in order to avoid the potential for hazardous events or substantial consequences should reverse flow occur.

3.1.18**cyclic service**

Refers to service conditions that may result in cyclic loading and produce fatigue damage or failure (e.g. cyclic loading from pressure, thermal, and/or mechanical loads). Other cyclic loads associated with vibration may arise from such sources as impact, turbulent flow vortices, resonance in compressors, and wind, or any combination thereof. Also see API/ASME 579-1/ASME FFS-1, Definition of Cyclic Service, in Section I.13 and screening methods in Annex B1.5, as well as the definition of "severe cyclic conditions" in ASME B31.3 Section 300.2, Definitions.

3.1.19**damage mechanism**

Any type of deterioration encountered in the refining and chemical process industry that can result in metal loss/flaws/defects that can affect the integrity of piping systems (e.g. corrosion; cracking; erosion; dents; and other mechanical, physical, or chemical impacts). See API 571 for a comprehensive list and description of damage mechanisms that may affect process piping systems in the refining, petrochemical and chemical process industries.

3.1.20**damage rate**

The rate of deterioration other than corrosion, i.e. rate of cracking, rate of HTHA, creep rate, etc.

3.1.21**deadlegs**

Components of a piping system that normally have little or no significant flow. Some examples include blanked (blinded) branches, lines with normally closed block valves, lines with one end blanked, pressurized dummy support legs, stagnant control valve bypass piping, spare pump piping, level bridles, pressure relieving device inlet and outlet header piping, pump trim bypass lines, high-point vents, sample points, drains, bleeders, and instrument connections. Deadlegs also include piping that is no longer in use but still connected to the process.

3.1.22**defect**

An imperfection of a type or magnitude exceeding the acceptance criteria.

3.1.23**deferral**

An approved and documented postponement of an inspection, test, or examination. See 7.13.

3.1.24**design pressure (of a piping component)**

The pressure at the most severe condition of coincident internal or external pressure and temperature (minimum or maximum) expected during service. It is the same as the design pressure defined in ASME B31.3 and other code sections and is subject to the same rules relating to allowances for variations of pressure or temperature or both.

design temperature (of a piping system component)

The temperature at which, under the coincident pressure, the greatest thickness or highest component rating is required. It is the same as the design temperature defined in ASME B31.3 and other code sections and is subject to the same rules relating to allowances for variations of pressure or temperature or both.

NOTE Different components in the same piping system or circuit can have different design temperatures. In establishing this temperature, consideration should be given to process fluid temperatures, ambient temperatures, heating/cooling media temperatures, and insulation.

3.1.25**due date**

The date established by the owner-user and in accordance with this code, whereby an inspection, test, examination, or inspection recommendation falls due or is to be completed. The date may be established by rule-based inspection methodologies (e.g. fixed intervals, retirement half-life interval, retirement date), risk-based methodologies (e.g. RBI target date), fitness-for-service analysis results, owner-user inspection agency practices/procedures/guidelines, or any combination thereof.

3.1.26**examination point**

Recording point measurement point test point. A specific location on a piping system to obtain a repeatable thickness measurement for the purpose of establishing an accurate corrosion rate. CMLs may contain multiple examination points.

NOTE Test point is a term no longer in use as "test" in this Code refers to mechanical or physical tests (e.g. tensile tests or pressure tests).

3.1.27**examinations**

The act of performing any type of NDE for the purpose of data collection and/or quality control functions performed by examiners.

NOTE Examinations would be typically those actions conducted by NDE personnel, welding or coating inspectors, but may also be conducted by authorized piping inspectors.

3.1.28**examiner**

A person who assists the inspector by performing specific NDE on piping system components and evaluates to the applicable acceptance criteria (where qualified to do so), but does not evaluate the results of those examinations in accordance with API 570 requirements, unless specifically trained and authorized to do so by the owner/user.

3.1.29**external inspection**

A visual inspection performed from the outside of a piping system to locate external issues that could impact the piping systems' ability to maintain pressure integrity (see 5.5.4). External inspections are also intended to find conditions that compromise the integrity of the coating and insulation covering, the supporting structures and attachments (e.g. stanchions, pipe supports, shoes, hangers, instrument, and small branch connections).

3.1.30**Fitness-For-Service evaluation**

An engineering methodology whereby flaws and other deterioration/damage contained within piping systems are assessed in order to determine the structural integrity of the piping for continued service (see API 579-1/ASME FFS-1).

3.1.31**fitting**

Piping component usually associated with a branch connection, a change in direction or change in piping diameter. Flanges are not considered fittings.

3.1.32**flammable materials**

As used in this Code, includes all fluids which will support combustion. Refer to NFPA 704 for guidance on classifying fluids in 6.3.4.

NOTE Some regulatory documents include separate definitions of flammables and combustibles based on their flash point. In this document flammable is used to describe both and the flash point, boiling point, auto ignition temperature or other properties are used in addition to better describe the hazard.

3.1.33**flash point**

The lowest temperature at which a flammable product emits enough vapor to form an ignitable mixture in air, (e.g. gasoline's flash point is about -45 °F, diesel's flash point varies from about 125 °F to 200 °F.)

NOTE An ignition source is required to cause ignition above the flash point, but below the auto-ignition temperature.

3.1.34**flaw**

An imperfection in a piping system usually detected by NDE which may or may not be a defect depending upon the applied acceptance criteria.

3.1.35**general corrosion**

Corrosion that is distributed more or less uniformly over the surface of the piping, as opposed to being localized in nature.

3.1.36**hold point**

A point in the repair or alteration process beyond which work may not proceed until the required inspection/examination has been performed and verified.

3.1.37**imperfection**

Flaws or other discontinuities noted during inspection that may be subject to acceptance criteria during an engineering and inspection analysis.

3.1.38**indication**

A response or evidence resulting from the application of a nondestructive evaluation technique.

3.1.39**industry-qualified UT angle beam examiner**

A person who possesses an ultrasonic angle beam qualification from API (e.g. API QUTE/QUSE Detection and Sizing Tests) or an equivalent qualification approved by the owner/user.

NOTE Rules for equivalency are defined on the API ICP website.

3.1.40 injection point

Injection points are locations where water, steam, chemicals or process additives are introduced into a process stream at relatively low flow/volume rates as compared to the flow/volume rate of the parent stream.

NOTE Corrosion inhibitors, neutralizers, process anti-foulants, de-salter demulsifiers, oxygen scavengers, caustic, and water washes are most often recognized as requiring special attention in designing the point of injection. Process additives, chemicals and water are injected into process streams in order to achieve specific process objectives. Injection points do not include locations where two process streams join (see 3.1.60, mixing points).

EXAMPLE Chlorinating agents in reformers, water injection in overhead systems, polysulfide injection in catalytic cracking wet gas, antifoam injections, inhibitors, and neutralizers.

3.1.41 in service

Designates a piping system that has been placed in operation as opposed to new construction prior to being placed in service or retired. A piping system not currently in operation due to a process outage is still considered to be in service. The operational stage of a piping system lifecycle that commences upon initial commissioning and ends when the piping system is finally retired from service or abandoned in place.

NOTE 1 Does not include piping systems that are still under construction or in transport to the site prior to being placed in service or piping systems that have been retired.

NOTE 2 Piping systems that are not currently in operation due to a temporary outage of the process, turnaround, or other maintenance activity are still considered to be "in service." Installed spare piping is also considered in service; whereas spare piping that is not installed is not considered in service.

3.1.42 in-service inspection

All inspection activities associated with piping after it has been initially placed in service but before it has been retired.

3.1.43 inspection

The external, internal, or on-stream evaluation (or any combination of the three) of piping condition conducted by the authorized inspector or his/her designee.

NOTE NDE may be conducted by examiners at the discretion of the responsible authorized piping inspector and become part of the inspection process, but the responsible authorized piping inspector shall review and approve the results.

3.1.44 inspection code

Shortened title for this Code (API 570).

3.1.45 inspection plan

A documented set of actions and strategies detailing the scope, extent, methods and timing of specific inspection activities in order to determine the condition of a piping system/circuit based on defined/expected damage. (see 5.1).

3.1.46 inspector

An authorized piping inspector per this inspection Code.

3.1.47 integrity operating window (IOW)

Established limits for process variables (parameters) that can affect the integrity of the equipment if the process operation deviates from the established limits for a predetermined amount of time. See 4.3.1.4.

3.1.48**intermittent Service**

The condition of a piping system whereby it is not in continuous operating service, i.e. it operates at regular or irregular intervals rather than continuously.

NOTE Occasional turnarounds or other infrequent maintenance outages in an otherwise continuous process service does not constitute intermittent service.

3.1.49**internal inspection**

An inspection performed on the inside surface of a piping system using visual and/or NDE methods (e.g. boroscope). NDE on the outside of the pipe to determine remaining thickness does not constitute an internal inspection.

3.1.50**jurisdiction**

A legally constituted governmental administration that may adopt rules relating to process piping systems.

3.1.51**level bridle**

The piping assembly associated with a level gauge attached to a vessel.

3.1.52**lining**

A nonmetallic or metallic material, installed on the interior of pipe, whose properties are better suited to resist damage from the process than the substrate material.

3.1.53**localized corrosion**

Deterioration restricted to isolated regions on a piping system, i.e. corrosion that is confined to a limited area of the metal surface (e.g. non-uniform corrosion).

3.1.54**lockout/tagout**

A safety procedure used to ensure that piping is properly isolated and cannot be energized or put back in service prior to the completion of inspection, maintenance, or servicing work.

3.1.55**major repairs**

Welding repairs that involve removal and replacement of large sections of piping systems.

3.1.56**management of change****MOC**

A documented management system for review and approval of changes (both physical and process) to piping systems prior to implementation of the change. The MOC process includes involvement of inspection personnel that may need to alter inspection plans as a result of the change.

3.1.57**material verification program**

A documented quality assurance procedure used to assess metallic alloy materials (including weldments and attachments where specified) to verify conformance with the selected or specified alloy material designated by the owner/user.

NOTE This program may include a description of methods for alloy material testing, physical component marking, and program recordkeeping (see API 578).

3.1.58
maximum allowable working pressure
MAWP

The maximum internal pressure permitted in the piping system for continued operation at the most severe condition of coincident internal or external pressure and temperature (minimum or maximum) expected during service. It is the same as the design pressure, as defined in ASME B31.3 and other code sections, and is subject to the same rules relating to allowances for variations of pressure or temperature or both. If the piping system is being rerated, the new MAWP shall be the rerated MAWP.

3.1.59
minimum alert thickness (flag thickness)

A thickness greater than the minimum required thickness that provides for early warning from which the future service life of the piping is managed through further inspection and remaining life assessment.

3.1.60
minimum design metal temperature/minimum allowable temperature
MDMT/MAT

The lowest permissible metal temperature for a given material at a specified thickness based on its resistance to brittle fracture. In the case of MAT, it may be a single temperature, or an envelope of allowable operating temperatures as a function of pressure. It is generally the minimum temperature at which a significant load can be applied to a piping system as defined in the applicable construction code. It might be also obtained through a Fitness-For-Service evaluation.

3.1.61
minimum required thickness

T_{min}

The thickness without corrosion allowance for each component of a piping system based on the appropriate design code calculations and code allowable stress that consider pressure, mechanical and structural loadings.

NOTE Alternately, minimum required thicknesses can be reassessed using Fitness-For-Service analysis in accordance with API 579-1/ASME FFS-1.

3.1.62
mixing point

Mixing points are locations in a process piping system where two or more streams meet. The difference in streams may be composition, temperature or any other parameter that may cause deterioration and may require additional design considerations, operating limits, inspection and/or process monitoring.

3.1.63
non-conformance

An item that is not in accordance with specified codes, standards or other requirements.

NOTE A non-conformance does not necessarily mean that the item is defective or that the item is not suitable for continued service.

3.1.64
nonpressure boundary

Components and attachments of, or the portion of piping that does not contain the process pressure.

EXAMPLE Clips, shoes, repads, supports, wear plates, nonstiffening insulation support rings, etc.

3.1.65
off-site piping

Piping systems not included within the plot boundary limits of a process unit, such as, a hydrocracker, an ethylene cracker or a crude unit.

EXAMPLE Tank farm piping and inter-connecting pipe rack piping outside the limits of the process unit.

3.1.66**on-site piping**

Piping systems included within the plot limits of process units, such as, a hydrocracker, an ethylene cracker, or a crude unit.

3.1.67**on-stream piping**

Piping systems that have not been isolated and decontaminated, i.e. still connected to in-service process equipment

NOTE Piping systems that are on-stream can be full of product during normal processing or empty or may still have residual process fluids in them and not be currently part of the process system (e.g. temporarily valved-out of service).

3.1.68**on-stream inspection**

An inspection performed from the outside of piping systems while they are on-stream using NDE procedures to establish the suitability of the pressure boundary for continued operation (see 5.5.2).

3.1.69**overdue inspection**

Inspections for in-service piping that remain in operation and have not been performed by the due date documented in the inspection plan, and have not been deferred by a documented deferral process. See 7.13.

3.1.70**overwater piping**

Piping located where leakage would result in discharge into streams, rivers, bays, etc., resulting in a potential environmental incident.

3.1.71**owner/user**

The organization that exercises control over the operation, engineering, inspection, repair, alteration, pressure testing, and rating of the piping systems.

3.1.72**owner/user inspector**

An authorized inspector employed by an owner/user who has qualified by examination under the provisions of Section 4 and Annex A.

3.1.73**pipe**

A pressure-tight cylinder used to convey, distribute, mix, separate, discharge, meter, control or snub fluid flows, or to transmit a fluid pressure and that is ordinarily designated "pipe" in applicable material specifications.

NOTE Materials designated as "tube" or "tubing" in the specifications are treated as pipe in this Code when intended for pressure service external to fired heaters. Piping internal to fired heaters should be in compliance with API 530.

3.1.74**piperack piping**

Process piping that is supported by consecutive stanchions or sleepers (including straddle racks and extensions).

3.1.75**piping circuit**

A subsection of piping systems that includes piping and components that are exposed to a process environment of similar corrosivity and expected damage mechanisms and is of similar design conditions and construction material where by the expected type and rate of damage can reasonably be expected to be the same.

NOTE 1 Complex process units or piping systems are divided into piping circuits to manage the necessary inspections, data analysis, and record keeping.

NOTE 2 When establishing the boundary of a particular piping circuit, it may be sized to provide a practical package for record keeping and performing field inspection.

3.1.76

piping engineer

One or more persons or organizations acceptable to the owner/user who are knowledgeable and experienced in the engineering disciplines associated with evaluating mechanical and material characteristics affecting the integrity and reliability of piping components and systems. The piping engineer, by consulting with appropriate specialists, should be regarded as a composite of all entities necessary to properly address piping design requirements.

3.1.77

pipe spool

A section of piping with a flange or other connecting fitting, such as a union, on both ends which allows the removal of the section from the system.

3.1.78

piping system

An assembly of interconnected pipe that typically are subject to the same (or nearly the same) process fluid composition and/or design conditions.

NOTE Piping systems also include pipe-supporting elements (e.g. springs, hangers, guides, etc.) but do not include support structures, such as structural frames, vertical and horizontal beams and foundations.

3.1.79

pitting

Localized corrosion of a metal surface in a small area and takes the form of cavities called pits. Pitting can be highly localized (including a single pit) or wide spread on a metal surface.

3.1.80

positive material identification

PMI

Any physical evaluation or test of a material to confirm that the material, which has been or will be placed into service, is consistent with the selected or specified alloy material designated by the owner/user.

NOTE These evaluations or tests can provide qualitative or quantitative information that is sufficient to verify the nominal alloy composition (see API 578).

3.1.81

postweld heat treatment

PWHT

A work process which consists of heating an entire weldment or section of fabricated piping to an elevated temperature after completion of welding in order to relieve the detrimental effects of welding heat, such as reducing residual stresses, reducing hardness, and/or slightly modifying properties (See ASME B31.3, paragraph 331).

3.1.82

pressure boundary

The portion of the piping that contains the pressure retaining piping elements joined or assembled into pressure tight fluid-containing piping systems. Pressure boundary components include pipe, tubing, fittings, flanges, gaskets, bolting, valves, and other devices such as expansion joints and flexible joints.

NOTE Also see non-pressure boundary definition.

3.1.83

pressure design thickness

Minimum allowed pipe wall thickness needed to hold the design pressure at the design temperature.

NOTE 1 Pressure design thickness is determined using the rating code formula, including needed reinforcement thickness.

NOTE 2 Pressure design thickness does not include thickness for structural loads, corrosion allowance, or mill tolerances and therefore should not be used as the sole determinant of structural integrity for typical process piping (e.g. 7.3).

3.1.84

primary process piping

Process piping in normal, active service that cannot be valved-off or, if it were valved off, would significantly affect unit operability. Primary process piping typically does not include small bore or auxiliary process piping (see also secondary process piping).

3.1.85

procedures

A document that specifies or describes how an activity is to be performed on a piping system, often a step-by-step description (e.g. temporary repair procedure, external inspection procedure, hot tap procedure, NDE procedure, etc).

NOTE A procedure may include methods to be employed, equipment or materials to be used, qualifications of personnel involved, and sequence of work.

3.1.86

process piping

Hydrocarbon or chemical piping located at, or associated with a refinery or manufacturing facility. Process piping includes piperack, tank farm, and process unit piping, but excludes utility piping (e.g. steam, water, air, nitrogen, etc).

3.1.87

quality assurance

All planned, systematic, and preventative actions required to determine if materials, equipment, or services will meet specified requirements so that the piping will perform satisfactorily in-service. Quality assurance plans will specify the necessary quality control activities and examinations.

NOTE The contents of a quality assurance inspection management system for piping systems are outlined in 4.3.1.

3.1.88

quality control

Those physical activities that are conducted to check conformance with specifications in accordance with the quality assurance plan (e.g. NDE techniques, hold point inspections, material verifications, checking certification documents, etc.).

3.1.89

renewal

Activity that discards an existing component, fitting, or portion of a piping circuit and replaces it with new or existing spare materials of the same or better qualities as the original piping components.

3.1.90

repair

The work necessary to restore a piping system to a condition suitable for safe operation at the design conditions.

NOTE If any of the restorative changes result in a change of design temperature or pressure, the requirements for re-rating also shall be satisfied. Any welding, cutting, or grinding operation on a pressure-containing piping component not specifically considered an alteration is considered a repair. Repairs can be temporary or permanent (see Section 8).

3.1.91

repair organization

Any of the following:

- a) an owner/user of piping systems who repairs or alters his or her own equipment in accordance with API 570,
- b) a contractor whose qualifications are acceptable to the owner/user of piping systems and who makes repairs or alterations in accordance with API 570,

- c) an organization that is authorized by, acceptable to, or otherwise not prohibited by the jurisdiction and who makes repairs in accordance with API 570.

3.1.92

rating

The work process of making calculations to establish pressures and temperatures appropriate for a piping system, including design pressure/temperature, MAWP, structural minimums, required thicknesses, etc.

3.1.93

rerating

A change in the design temperature, design pressure or the maximum allowable working pressure of a piping system (sometimes called rating).

NOTE A rerating may consist of an increase, a decrease, or a combination of both. Derating below original design conditions is a means to provide increased corrosion allowance.

3.1.94

retired from service

Piping systems that are no longer going to be used for any process service.

3.1.95

Risk-based inspection

RBI

A risk assessment and risk management process that is focused on inspection planning for piping systems for loss of containment in processing facilities, which considers both the probability of failure and consequence of failure due to materials of construction deterioration. See 5.2.

3.1.96

scanning

The movement of a device (visual, ultrasonic, etc.) over a wide area as opposed to a spot reading and used to find flaws/defects (e.g. the thinnest thickness measurement at a CML or cracking in a weldment). See guidance contained in API 574.

3.1.97

secondary process piping

Process piping located downstream of a block valve that can be valved-off without significantly affecting the process unit operability is commonly referred to as secondary process piping. Often, secondary process piping is small-bore piping (SBP).

3.1.98

small-bore piping

SBP

Pipe or pipe components that are less than or equal to NPS 2.

3.1.99

soil-to-air interface

SAI

An area in which external corrosion may occur or be accelerated on partially buried pipe or buried pipe near where it egresses from the soil.

NOTE The zone of the corrosion will vary depending on factors such as moisture, oxygen content of the soil, and operating temperature. The zone generally is considered to be at least 12 in. (305 mm) below to 6 in. (150 mm) above the soil surface. Pipe running parallel with the soil surface that contacts the soil is included.

3.1.100**structural minimum thickness**

Minimum required thickness without corrosion allowance, based on the mechanical loads other than pressure that result in longitudinal stress. See 7.6.

NOTE The thickness is either determined from a standard chart or engineering calculations. It does not include thickness for corrosion allowance or mill tolerances.

3.1.101**temporary repairs**

Repairs made to piping systems in order to restore sufficient integrity to continue safe operation until permanent repairs can be scheduled and accomplished within a time period acceptable to the inspector and/or piping engineer

NOTE Injection fittings on valves to seal fugitive (LDAR) emissions from valve stem seal are not considered to be "temporary repairs" as described in 8.1.4.1 and 8.1.5 in this Code.

3.1.102**testing**

Procedures used to determine pressure tightness, material hardness, strength, and notch toughness.

EXAMPLE Example: Pressure testing, whether performed hydrostatically, pneumatically, or a combination of hydrostatic/pneumatic or mechanical testing.

NOTE Testing does not refer to NDE using techniques such as PT, MT, etc.

3.1.103**tank farm piping**

Process piping inside tank farm dikes or directly associated with a tank farm.

3.1.104**utility piping**

Non-process piping associated with a process unit (e.g. steam, air, water, nitrogen, etc.)

3.2 Acronyms and Abbreviations

API	American Petroleum Institute
ASME	American Society of Mechanical Engineers
ASNT	American Society for Nondestructive Testing
AUT	Automated Ultrasonic Examination
BPVC	boiler and pressure vessel code (of ASME)
CMB	computerized monitoring button
CML	condition monitoring location
CP	cathodic protection
CUI	corrosion under insulation, including stress corrosion cracking under insulation
EMAT	electromagnetic acoustic transducer
ECSCC	external chloride stress corrosion cracking
ET	Eddy current technique
FFS	Fitness-for-Service
FRP	fiberglass reinforced plastic
GWT	guided wave examination
HIC	hydrogen induced cracking

ID	Inside diameter
ILI	in-line inspection
IOW	integrity operating window
ISO	inspection isometric drawing
LDAR	leak detection and repair (of fugitive emissions)
LT	long term
MAT	minimum allowable temperature
MAWP	maximum allowable working pressure
MDMT	minimum design metal temperature
MDR	manufacturer's data reports
MFL	magnetic flux leakage
MOC	management of change
MT	magnetic-particle technique
MTR	material test report (mill test report)
NACE	NACE International, the Corrosion Society, previously National Association of Corrosion Engineers
NDE	nondestructive examination
NPS	nominal pipe size (followed, when appropriate, by the specific size designation number without an inch symbol)
OD	outside diameter
OSHA	Occupational Safety and Health Administration
PAUT	phased array ultrasonic technique
PCC	Post Construction Committee (of ASME)
PEC	pulsed eddy current
PMI	positive material identification
PQR	procedure qualification record
PRD	pressure relieving device
PRT	profile radiographic examination
PT	liquid-penetrant technique
PWHT	post-welding heat treatment
RBI	risk-based inspection
RFID	radio frequency identification devices
RT	radiographic examination (method) or radiography
RTP	reinforced thermoset plastic
SAI	soil air interface
SCC	stress corrosion cracking
SBP	small-bore piping
SDO	standards development organization (e.g. API, ASME, NACE)
ST	short term
SMYS	specified minimum yield strength
TML	thickness monitoring location
UT	ultrasonic technique

WPS welding procedure specification

4 Owner/User Inspection Organization

4.1 General

An owner/user of piping systems shall exercise control of the piping system inspection program, inspection frequencies, and maintenance and is responsible for the function of an authorized inspection agency in accordance with the provisions of API 570. The owner/user inspection organization also shall control activities relating to the rating, repair, and alteration of its piping systems. See definition of authorized inspection agency.

4.2 Authorized Piping Inspector Qualification and Certification

Authorized piping inspectors shall have education and experience in accordance with Annex A of this inspection Code. Authorized piping inspectors shall be certified in accordance with the provisions of Annex A. Whenever the term inspector is used in this Code, it refers to an authorized piping inspector.

4.3 Responsibilities

4.3.1 Owner/User Organization

4.3.1.1 Systems and Procedures

An owner/user organization is responsible for developing, documenting, implementing, executing, and assessing piping inspection systems and inspection procedures that will meet the requirements of this inspection Code. These systems and procedures will be contained in a quality assurance inspection/repair management system and shall include:

- a) organization and reporting structure for inspection personnel;
- b) documenting and maintaining inspection and quality assurance procedures;
- c) documenting and reporting inspection and test results;
- d) developing and documenting inspection plans;
- e) developing and documenting risk-based assessments;
- f) developing and documenting the appropriate inspection intervals;
- g) corrective action for inspection and test results;
- h) internal auditing for compliance with the quality assurance inspection manual;
- i) review and approval of drawings, design calculations, and specifications for repairs, alterations, reratings and FFS assessments;
- j) ensuring that all jurisdictional requirements for piping inspection, repairs, alterations, and rerating are continuously met;
- k) reporting to the authorized piping inspector any process changes that could affect piping integrity;

- l) training requirements for inspection personnel regarding inspection tools, techniques, and technical knowledge base;
- m) controls necessary so that only qualified welders and procedures are used for all repairs and alterations;
- n) controls necessary so that only qualified NDE personnel and procedures are utilized;
- o) controls necessary so that only materials conforming to the applicable section of the ASME Code are utilized for repairs and alterations;
- p) controls necessary so that all inspection measurement and test equipment are properly maintained and calibrated;
- q) controls necessary so that the work of contract inspection or repair organizations meet the same inspection requirements as the owner/user organization and this inspection Code;
- r) internal auditing requirements for the quality control system for pressure-relieving devices;
- s) controls required to ensure that inspectors have the visual acuity necessary to perform their assigned inspection tasks.

4.3.1.2 Inspection Organization Audits

Each owner/user organization should be audited periodically to determine if they are meeting the requirements of an authorized inspection agency as defined in this inspection Code. The audit team should consist of people experienced and competent in the application of this Code. The audit team should typically be from another owner/user plant site, company central office or from a third party organization experienced and competent in refining and/or petrochemical process plant inspection programs or a combination of third party and other owner/user sites.

The following key elements of an inspection program should be assessed by the audit team:

- a) the requirements and principles of this inspection Code are being met;
- b) owner/user responsibilities are being properly discharged;
- c) documented inspection plans are in place for covered piping systems;
- d) intervals and extent of inspections are adequate for covered piping systems;
- e) general types of inspections and surveillance are being adequately applied;
- f) inspection data analysis, evaluation, and recording are adequate;
- g) repairs, reratings and alterations comply with this Code.

The owner/user should receive a report of the audit team's scope and findings. After review of the report, non-conformances should be prioritized and corrective actions implemented. Each organization should establish a system for tracking and completion of audit findings. This information should also be reviewed during subsequent audits.

4.3.1.3 MOC

The owner/user is also responsible for implementing an effective MOC process that will review and control changes to the process and to the hardware. An effective MOC process is vital to the success of any piping integrity management program in order that the inspection group is able to: 1) address issues concerning the adequacy of the

pressure piping design and current condition for the proposed changes, 2) anticipate changes in corrosion or other types of damage and their effects on the adequacy on the pressure piping, and 3) update the inspection plan and records to account for those changes. The MOC process shall include the appropriate materials/corrosion experience and expertise in order to effectively forecast what changes might affect piping integrity. The inspection group shall be involved in the approval process for changes that may affect piping integrity. Changes to the hardware and the process shall be included in the MOC process to ensure its effectiveness.

4.3.1.4 Integrity Operating Windows (IOWs)

The owner/user should implement and maintain an effective program for creating, establishing and monitoring integrity operating windows. IOWs are implemented to avoid process parameter exceedances that may have an unanticipated impact on pressure equipment integrity. Future inspection plans and intervals have historically been based on prior measured corrosion rates resulting from past operating conditions. Without an effective IOW and process control program, there often is no warning of changing operating conditions that could affect the damage mechanisms and rates and subsequently impact the integrity of equipment, or validation of the current inspection plan. Deviations from and changes of trends within established IOW limits should be brought to the attention of inspection/engineering personnel so they may modify or create new inspection plans depending upon the seriousness of the exceedance.

Integrity operating windows should be established for process parameters (both physical and chemical) that could impact equipment integrity if not properly controlled. Examples of the process parameters include temperatures, pressures, fluid velocities, pH, flow rates, chemical or water injection rates, levels of corrosive/erosive constituents, chemical composition, etc. IOWs for key process parameters may have both upper and lower limits established, as needed. Particular attention to monitoring integrity operating windows should also be provided during start-ups, shutdowns and significant process upsets. See API 584 for more information on issues that may assist in the development of an IOW program.

4.3.2 Piping Engineer

The piping engineer is responsible to the owner/user for activities involving design, engineering review, rating, analysis, or evaluation of piping systems and PRDs covered by API 570 as specified in this Code.

4.3.3 Repair Organization

All repairs and alterations shall be performed by a repair organization as defined in Section 3. The repair organization shall be responsible to the owner/user and shall provide the materials, equipment, quality control, and workmanship necessary to maintain and repair the piping systems in accordance with the requirements of API 570.

4.3.4 Authorized Piping Inspector

When inspections, repairs, or alterations are being conducted on piping systems, the designated authorized piping inspector shall be responsible to the owner/user for determining that the requirements of API 570 on inspection, examination, quality assurance and testing are met. The inspector shall be directly involved in the inspection activities which in most cases will require field activities to ensure that procedures are followed. The inspector is also responsible for extending the scope of the inspection (with appropriate consultation with engineers/specialists), where justified depending upon the findings of the inspection. Where non-conformances are discovered, the designated inspector is responsible for notifying the owner/user in a timely manner and making appropriate repair or other mitigative recommendations.

The inspector shall be knowledgeable with piping system damage types listed in API 571 and the content of API 574, API 576, API 577, API 578, API 583, API 584, and also knowledgeable in RP 580 where RBI is in use. The inspector shall be able to use the guidance contained in these RPs in order to meet the requirements and/or expectations in this Code.

The authorized piping inspector may be assisted in performing visual inspections by other properly trained and qualified individuals, who may or may not be certified piping inspectors (e.g. examiners and operating personnel). Personnel performing NDEs shall meet the qualifications identified in 4.3.5, but need not be authorized piping inspectors. However, all examination results shall be evaluated and accepted by the authorized piping inspector. See definition of an authorized piping inspector..

4.3.5 Examiners

The examiner shall perform the NDE in accordance with job requirements. See definition of an examiner.

The examiner is not required to be certified in accordance with Annex A and does not need to be an employee of the owner/user. The examiner shall be trained and competent in the NDE procedures being used and may be required by the owner/user to prove competency by holding certifications in those procedures. Examples of other certifications that may be required include ASNT SNT-TC-1A [2], ASNT CP-189 [2], and AWS QC1 [2]. Inspectors conducting their own examinations with NDE techniques shall also be appropriately qualified in accordance with owner/user requirements and appropriate industry standards.

The examiner's employer shall maintain certification records of the examiners employed, including dates and results of personnel qualifications. These records shall be available to the inspector.

4.3.6 Other Personnel

Operating, maintenance, engineering (process and mechanical) or other personnel who have special knowledge or expertise related to particular piping systems shall be responsible for timely notification to the inspector and/or engineer of issues that may affect piping integrity such as the following:

- a) any action that requires MOC or inspection activity as a result of an MOC;
- b) operations outside defined integrity operating windows (IOW's);
- c) changes in source of feedstock and other process fluids that could increase process related corrosion rates or introduce new damage mechanisms;
- d) piping failures, repair actions conducted and failure analysis reports;
- e) cleaning and decontamination methods used or other maintenance procedures that could affect piping and equipment integrity;
- f) reports from other plants' experiences that have come to their attention regarding similar service piping and associated equipment failures;
- g) any unusual conditions that may develop (e.g. noises, leaks, vibration, movement, insulation damage, external piping deterioration, support structure deterioration, significant bolting corrosion, etc.);
- h) any engineering evaluation, including FFS assessments, that might require current or future actions to maintain mechanical integrity until next inspection.

5 Inspection, Examination, and Pressure Testing Practices

5.1 Inspection Plans

5.1.1 Piping Systemization and Circuitization

In order to develop inspection plans (including scope, frequency, techniques and location), facility piping should be broken down into piping systems and circuits. Piping systems can be defined at a PFD (process flow diagram) level however piping circuits are often defined at the P&ID (process and instrumentation diagram) level. Potential damage mechanisms are primarily a function of the process/operating conditions, the material of construction and mechanical design. Defining systems and circuits based upon potential damage mechanisms can yield an inspection plan with a high probability of detecting damage. The Piping systemization is the first cut for defining the potential corrosion issues and is a convenient reference to the general location of damage mechanisms within the process unit. Piping systems generally have common characteristics such as one or more of the following:

- a) process intent (e.g. overhead reflux system),
- b) process control scheme (e.g. temperature/end point),
- c) process stream composition,
- d) design operating conditions,
- e) similar or related set of IOWs.

Piping systems may contain (or pass through) one or more equipment items (e.g. exchangers, pumps) and will typically contain one or multiple piping circuits. Piping systems and circuits developed from expected/identified damage mechanisms enables the development of concise inspection plans and forms the basis for improved data analysis. Piping circuitization is a further breakdown of piping systems into sections of piping and/or individual pipe components which have common damage mechanisms, same material of construction and have similar damage rates and modes.

Refer to API 574 for more information on development of piping systems and circuits.

5.1.2 Development of an Inspection Plan

An inspection plan shall be established for all piping systems and/or circuits and associated pressure relieving devices within the scope of this Code. The inspection plan shall be developed by the inspector and/or engineer. A corrosion specialist shall be consulted to identify/clarify potential damage mechanisms and specific locations where degradation may occur, especially where localized corrosion or cracking mechanisms may be involved. A corrosion specialist shall be consulted when developing the inspection plans for piping systems that operate at elevated temperatures [above 750 °F (400 °C)] and piping systems that operate below the ductile-to-brittle transition temperature. Special attention in the inspection plan should be given to any types of deterioration or issues listed in 5.5.2.

The inspection plan is developed from the analysis of several sources of data including the piping inspection records. Piping systems shall be evaluated based on present or possible types of damage mechanisms. The methods and the extent of NDE shall be evaluated to assure that they can adequately identify the damage mechanism and the severity of damage. Subdividing piping systems into circuits subject to common damage mechanisms facilitates selecting the inspection techniques best suited to find the damage that's most likely to occur in the piping circuit. Examinations shall be scheduled at intervals that consider the:

- a) type of damage (see API 571),

- b) rate of damage progression,
- c) tolerance of the equipment to the type of damage,
- d) capability of the NDE method to identify the damage,
- e) maximum intervals as defined in codes and standards,
- f) extent of examination,
- g) Recent operating history, including IOW exceedances;
- h) MOC records that may impact inspection plans;
- i) RBI assessments or piping classification.

The inspection plan should be developed using the most appropriate sources of information including those references listed in Section 2. Inspection plans shall be reviewed and amended as needed when variables that may impact damage mechanisms and/or deterioration rates are identified such as those contained in inspection reports or management of change documents. See API 574 for more information on the development of inspection plans.

5.1.3 Minimum Contents of an Inspection Plan

The inspection plan shall contain the inspection tasks and schedule required to monitor identified damage mechanisms and assure the pressure integrity of the piping systems. The plan should:

- a) define the type(s) of inspection needed, (e.g. internal, external, on-stream ,nonintrusive);
- b) identify the next inspection date for each inspection type;
- c) describe the inspection methods and NDE techniques;
- d) describe the extent and locations of inspection and NDE at CMLs;
- e) describe the surface cleaning requirements needed for inspection and examinations for each type of inspection;
- f) describe the requirements of any needed pressure test (e.g. type of test, test pressure, test temperature, and duration);
- g) describe any required repairs if known or previously planned before the upcoming inspection.
- h) describe the types of damage anticipated or experienced in the piping systems;
- i) define the location of the expected damage;
- j) define any special access and preparation needed.

Generic inspection plans based on industry standards and practices may be used as a starting point in developing specific inspection plans. The inspection plan may or may not exist in a single document, however the contents of the plan should be readily accessible from inspection data systems.

5.2 RBI

5.2.1 General

An RBI analysis may be used to determine inspection intervals or due dates and the type and extent of future inspection/examinations. The RBI analysis, when conducted in accordance with API 580, shall include all of the inspection planning elements noted in API 580, Section 5.2.

When the owner/user chooses to conduct an RBI assessment it shall include a systematic evaluation of both the probability and the associated consequence of failure, in accordance with the requirements in API 580. API 581 provides a set of methodologies for assessing risk (both POF and COF) and for developing inspection plans that are consistent with key elements defined in API 580.

Identifying and evaluating potential damage mechanisms, current equipment condition and the effectiveness of the past inspections are important steps in assessing the probability of piping failure. Identifying and evaluating the process fluid(s), potential injuries, environmental damage, equipment damage and equipment downtime are important steps in assessing the consequence of piping failure. Identifying integrity operating windows for key process variables is an important adjunct to RBI (see 4.3.1.4).

5.2.2 Probability Assessment

The probability assessment shall be in accordance with the requirements in API 580 and shall be based on all forms of damage that could reasonably be expected to affect equipment in any particular service. Additionally, the effectiveness of the inspection practices, tools, and techniques used for finding the potential damage mechanisms shall be evaluated.

Other factors that should be considered in a probability assessment include:

- a) appropriateness of the materials of construction for the damage mechanisms;
- b) equipment design conditions, relative to operating conditions;
- c) appropriateness of the design codes and standards utilized;
- d) effectiveness of corrosion monitoring programs;
- e) the quality of maintenance and inspection quality assurance/quality control programs;
- f) both the pressure retaining and structural requirements;
- g) operating conditions both past and projected and review of potential fouling as it impacts damage mechanisms;
- h) prior mechanical / corrosion or failure history of the piping system/circuit;
- i) review of inspection history.

5.2.3 Consequence Assessment

The consequence of a release is dependent on type and amount of process fluid contained in the equipment. The consequence assessment shall be in accordance with the requirements in API 580 and shall consider the potential incidents that may occur as a result of fluid release, the size of a potential release, and the type of a potential release (includes explosion, fire, or toxic exposure.) The assessment should also determine the potential outcomes that may occur as a result of fluid release or equipment damage, which may include: health effects, environmental impact, additional equipment damage, and process downtime or slowdown.

5.2.4 Documentation

It is essential that all RBI assessments be thoroughly documented in accordance with the requirements in API 580 clearly defining all the factors contributing to both the probability and consequence of a failure of the equipment.

After an RBI assessment is conducted, the results can be used to establish the equipment inspection plan and better define the following:

- a) the most appropriate inspection and NDE methods, tools, and techniques;
- b) the extent of NDE (e.g. percentage of equipment to examine);
- c) the interval or due date for internal (where applicable), external, and on-stream inspections;
- d) the need for pressure testing after damage has occurred or after repairs/alterations have been completed;
- e) the prevention and mitigation steps to reduce the probability and consequence of equipment failure. (e.g. repairs, process changes, inhibitors, etc.).

5.2.5 Frequency of RBI Assessments

When RBI assessments are used to set equipment inspection intervals or due dates, the assessment shall be updated after each equipment inspection as defined in API 580 Section 15. The RBI assessment shall be updated at least every 10 years or more often if process or hardware changes are made, or after any event occurs that could significantly affect damage rates or damage mechanisms.

The RBI assessment shall be reviewed and approved by the appropriate qualified personnel per API 580 and inspector.

5.3 Preparation for Inspection

5.3.1 General

Safety precautions shall be included when preparing piping systems for inspection and maintenance activities to eliminate exposure to hazardous fluids, energy sources, and physical hazards. Regulations [e.g. those administered by the U.S. Occupational Safety and Health Administration (OSHA)] govern many aspects of piping systems inspection and shall be followed where applicable. In addition, the owner/user's safety procedures shall be reviewed and followed. See API 574 for more information on the safety aspects of piping inspection.

Procedures for segregating piping systems, installing blinds (blanks), and testing tightness should be an integral part of safety practices for flanged connections. Appropriate safety precautions shall be taken before any piping system is opened. In general, the section of piping to be opened should be isolated from all sources of harmful liquids, gases, or vapors and purged to remove all oil and toxic or flammable gases and vapors. See API 574 for more information on the equipment preparation and entry aspects of piping inspection.

5.3.2 Records Review

Before performing any of the required inspections, inspectors shall familiarize themselves with prior history of the piping system for which they are responsible. In particular, they should review the piping system's prior inspection results, prior repairs, current inspection plan, and/or other similar service inspections. Additionally it is advisable to ascertain recent operating history that may affect the inspection plan. The types of damage and failure modes experienced by piping systems are provided in API 571 and API 579-1/ASME FFS-1.

5.4 Inspection for Types and Locations of Damage Modes of Deterioration and Failure

5.4.1 Piping System Damage Types

API 571 describes common damage mechanisms and inspection techniques to identify them. Some example mechanisms applicable to process piping systems are as follows:

a) General and localized metal loss:

- 1) sulfidation and high temperature H₂S/H₂ corrosion; refer to API 571 Sections 4.4.2 and 5.1.1.5 and API 939-C;
- 2) oxidation; refer to API 571 Section 4.4.1;
- 3) microbiologically induced corrosion (MIC); refer to API 571 Section 4.3.8;
- 4) naphthenic acid corrosion; refer to API 571 Section 5.1.1.7;
- 5) erosion/erosion-corrosion; refer to API 571 Section 4.2.14;
- 6) galvanic corrosion; refer to API 571 Section 4.3.1;
- 7) atmospheric corrosion; refer to API 571 Section 4.3.2;
- 8) corrosion under insulation (CUI); refer to API 571 Section 4.3.3;
- 9) cooling water corrosion; refer to API 571 Section 4.3.4;
- 10) boiler water condensate corrosion; refer to API 571 Section 4.3.5;
- 11) soil corrosion; refer to API 571 Section 4.3.9;
- 12) ammonium bisulfide and chloride corrosion; refer to API 571 Sections 5.1.1.2 and 5.1.1.3;
- 13) carbon dioxide corrosion; refer to API 571 Section 4.3.6.

b) Surface connected cracking:

- 1) mechanical fatigue cracking; refer to API 571 Section 4.2.16;
- 2) thermal fatigue cracking; refer to API 571 Section 4.2.9;
- 3) caustic stress corrosion cracking; refer to API 571 Section 4.5.3;
- 4) polythionic stress corrosion cracking; refer to API 571 Section 5.1.2.1;
- 5) sulfide stress cracking; refer to API 571 Section 5.1.2.3;
- 6) chloride stress corrosion cracking; refer to API 571 Section 4.5.1.

c) Subsurface cracking:

- 1) hydrogen induced cracking; refer to API 571 Section 4.4.2;
- 2) wet hydrogen sulfide cracking; refer to API 571 Section 5.1.2.3.

d) High-temperature micro-fissuring/micro-void formation and eventual macro-cracking:

- 1) high-temperature hydrogen attack; refer to API 941, Section 6;
- 2) creep/stress rupture; refer to API 571 Section 4.2.8.

e) Metallurgical changes:

- 1) graphitization; refer to API 571 Section 4.2.1;
- 2) temper embrittlement; refer to API 571 Section 4.2.3;
- 3) hydrogen embrittlement; refer to API 571 Section 4.5.6.

f) Blistering:

- 1) hydrogen blistering; refer to API 571 Section 5.1.2.3.

The presence or potential of damage in equipment is dependent upon its material of construction, design, construction, and operating conditions. The inspector should be familiar with these conditions and with the causes and characteristics of potential defects and damage mechanisms associated with the equipment being inspected.

Detailed information concerning common damage mechanisms (critical factors, appearance, and typical inspection and monitoring techniques) is found in API 571 and other sources of information on damage mechanisms included in the bibliography. Additional recommended inspection practices for specific types of damage mechanisms are described in API 574.

5.4.2 Areas of Deterioration for Piping Systems

Each owner/user shall provide specific attention to the need for inspection of piping systems that are susceptible to the following specific types and areas of deterioration:

- a) injection points and mixing points,
- b) deadlegs,
- c) CUI including ECSCC inspection,
- d) Soil-to-air interfaces and soil corrosion of buried piping,
- e) service specific and localized corrosion,
- f) erosion and corrosion/erosion,
- g) environmental cracking,
- h) corrosion beneath linings and deposits,
- i) fatigue cracking,
- j) creep cracking,
- k) freeze damage,

- l) contact point corrosion.

NOTE Brittle fracture is not normally mitigated by inspection but the owner/users should be aware of the potential for brittle fracture for some materials of construction exposed to specific temperature and stress conditions and manage the risk appropriately (e.g. managing with process controls).

Refer to API 571 and API 574 for more detailed information about the above noted types and areas of deterioration.

5.5 General Types of Inspection and Surveillance

5.5.1 General

Different types of inspection and surveillance are appropriate depending on the circumstances and the piping system. These include the following types of inspections and inspection focus areas:

- a) internal visual inspection,
- b) on-stream inspection,
- c) thickness measurement inspection,
- d) various NDE examinations,
- e) external visual inspection,
- f) vibrating piping inspection,
- g) supplemental inspection.

Inspections shall be conducted in accordance with the inspection plan for each piping circuit or system. Refer to Section 6 for the interval/frequency and extent of inspection. Corrosion and other damage identified during inspections and examinations shall be characterized, sized, and evaluated per Section 7. Revisions to the inspection plan shall be approved by the inspector and/or piping engineer.

5.5.2 Internal Visual Inspection

Internal visual inspections are not normally performed on piping. When practical, internal visual inspections may be scheduled for systems such as large-diameter transfer lines, ducts, catalyst lines, or other large-diameter piping systems. Such inspections are similar in nature to pressure vessel inspections and should be conducted with methods and procedures similar to those outlined in API 510 and API 572. Remote visual inspection techniques can be helpful when inspecting piping which is too small to enter.

An additional opportunity for internal inspection is provided when piping flanges are disconnected, allowing visual inspection of internal surfaces with or without the use of NDE. When piping flanges are disconnected, the gasket surface, studs and nuts should be examined for any signs of deterioration. Removing a section of piping and splitting it along its centerline also permits access to internal surfaces where there is need for such inspection.

5.5.3 On-stream Inspection

The on-stream inspection may be required by the inspection plan. All on-stream inspections should be conducted by either an inspector or examiner. All on-stream inspection work performed by an examiner shall be authorized and approved by the inspector. When on-stream inspections of the pressure boundary are specified, they shall be designed to detect the damage mechanisms identified in the inspection plan.

The inspection may include several NDE techniques to check for various types of damage that pertain to the circuit as identified during inspection planning. Techniques used in on-stream inspections are chosen for their ability to identify particular damage mechanisms from the exterior and their capabilities to perform at the on-stream conditions of the piping system (e.g. metal temperatures). The external thickness measurement inspection described in 5.6.2 may be a part of an on-stream inspection.

There are inherent limitations when applying external NDE techniques trying to locate damage on the inside of piping components. Issues that can affect those limitations include:

- a) type of material of construction (alloy);
- b) weldments;
- c) pipe junctions, nozzles, support saddles, reinforcing plates;
- d) internal lining or cladding;
- e) physical access and equipment temperature;
- f) limitations inherent to the selected NDE technique to detect the damage mechanism;
- g) type of damage mechanism (e.g. pitting versus general wall thinning).

API 574 provides more information on piping system inspection and should be applied when performing on-stream piping inspections.

5.5.4 Thickness Measurement Inspection and Various NDE Examinations

Thickness measurements are obtained to verify the thickness of piping components. This data is used to calculate the corrosion rates and remaining life of the piping system. Thickness measurements shall be obtained by the inspector or the examiner at the direction of the inspector. The owner/user shall ensure that all individuals conducting thickness measurements are trained and qualified in accordance with the applicable procedure used during the examination.

Normally thickness measurements are taken while the piping is on-stream. On-stream thickness monitoring is a good tool for monitoring corrosion and assessing potential damage due to process or operational changes.

The inspector should consult with a corrosion specialist when the short-term corrosion rate changes significantly from the previous identified rate to determine the cause. Appropriate responses to accelerated corrosion rates may include, obtaining additional UT thickness readings, using profile RT in lieu of, or to supplement UT readings, performing UT scans in suspect areas, performing other corrosion/process monitoring, reviewing changes in operations/process, making revisions to the piping inspection plan and addressing non-conformances.

Screening examination techniques (e.g. guided wave examination, EMAT, Lamb wave) are typically limited to the qualitative data results (i.e. volumetric percentage of wall loss, versus actual discrete thickness values). If used, screening examination techniques are considered to fulfill the requirements for thickness measurement inspection provided they are used complimentary to an inspection plan that also includes periodic quantitative examination techniques to establish actual baseline thickness data, or to prove up screening technique examination results conducted at appropriate intervals.

See API 574, Third Edition, Section 10.2, *Thickness Measurement*, for additional guidance in conducting ultrasonic thickness measurements.

5.5.5 External Visual Inspection

An external visual inspection is performed to determine the condition of the outside of the piping, insulation system, painting, and coating systems, and associated hardware; and to check for signs of misalignment, vibration, and leakage. When corrosion product buildup or other debris is noted at pipe support contact areas, it may be necessary to lift the pipe off such supports for thorough inspection. When lifting piping that is in operation, extra care should be exercised and consultation with an engineer may be necessary. Based on the support type/configuration, screening techniques such as guided wave testing/EMAT or Lamb-wave inspections can be used to locate areas of interest for follow-up inspection using more quantitative NDE techniques. Users of screening techniques should be aware of the possibility that some of those techniques may miss significant localized corrosion. External piping inspections may be made when the piping system is on-stream. Refer to API 574 for information concerning conducting external inspections. External piping inspections may include CUI inspections per 5.6.5.

External inspections shall include surveys for the condition of piping hangers and supports. Instances of cracked or broken hangers, "bottoming out" of spring supports, support shoes displaced from support members, or other improper restraint conditions shall be reported and corrected. Vertical support dummy legs also shall be checked to confirm that they have not filled with water that is causing external corrosion of the pressure piping or internal corrosion of the support leg. Horizontal support dummy legs also shall be checked to determine that slight displacements from horizontal are not causing moisture traps against the external surface of active piping components.

Bellows expansion joints should be inspected visually for unusual deformations, misalignment, excessive angular rotation and displacements that may exceed design. In some cases where two ply bellows have been utilized, the annular space between the inner and outer bellow should be pressure tested and/or monitored for leakage. Other nonstandard piping components (e.g. flex hoses) may have different degradation mechanisms (see API 574). Specialist engineers or manufacturer data sources may need to be consulted in developing valid inspection plans for these components. The inspector should examine the piping system for the presence of any field modifications or temporary repairs not previously recorded on the piping drawings and/or records. The inspector also should be alert to the presence of any components that may be unsuitable for long-term operation, such as improper flanges, temporary repairs (clamps), modifications (flexible hoses), or valves of improper specification. Threaded components and other flanged spool pieces that may be easily removed and reinstalled deserve particular attention because of their higher potential for installation of incorrect materials of construction.

The periodic external inspection called for in 6.4 should normally be conducted by the inspector, who also shall be responsible for record keeping and repair inspection. Qualified examiners, operating or maintenance personnel may also conduct external inspections, when acceptable to the inspector. In such cases, the persons conducting external piping inspections in accordance with API 570 shall be qualified through an appropriate amount of training.

In addition to these scheduled external inspections that are documented in inspection records, it is beneficial for personnel who frequent the area to report deterioration or changes to the inspector (see API 574 for examples of such deterioration).

During the external inspection, particular attention should be given to weldments of attachments (e.g. reinforcement plates and clips) looking for cracking, corrosion or other defects. Any signs of leakage should be investigated so that the sources can be established. Normally, weep holes in reinforcing plates (re-pads) should remain open to provide visual evidence of leakage. If weep holes are plugged to exclude moisture they shall not be plugged with material capable of sustaining pressure behind the reinforcing plate unless fitness for service assessments and an approved MOC have demonstrated that the reinforcement plate is capable of withstanding the design pressure of the piping system.

5.5.6 Vibrating Piping and Line Movement Surveillance

Operating personnel should report vibrating or swaying piping to engineering or inspection personnel for assessment. Evidence of significant line movement that could have resulted from liquid hammer (e.g. piping shifted off of pipe

support's normal/designed location), liquid slugging in vapor lines, abnormal thermal expansion or from other sources such as large reciprocating compressors, should be reported. At locations where vibrating piping systems are restrained to resist dynamic pipe stresses (such as at shoes, anchors, guides, struts, dampeners, hangers), periodic MT or PT should be considered to check for the onset of fatigue cracking. Branch connections should receive special attention particularly unbraced small bore piping connected to vibrating pipe. However, fatigue is generally considered to be a design related mechanism. Once a crack has initiated, it can grow at unknown rates and inspection alone cannot be used to manage the risk of failure. Typically at the point a fatigue crack is detectible, approximately 80 % of the life has been consumed and failure can occur prior to the next scheduled inspection cycle without careful engineering assessment/analysis.

5.5.7 Supplemental Inspection

Other inspections may be scheduled as appropriate or necessary. Examples of such inspections include periodic use of radiography and/or thermography to check for fouling or internal plugging, thermography to check for hot spots in refractory lined systems, additional inspections after reported process unit upsets, verifying previously measured data for accuracy, inspection for environmental cracking, and any other piping specific damage mechanism. Acoustic emission, acoustic leak detection, and thermography can be used for remote leak detection and surveillance. Areas susceptible to localized erosion or erosion-corrosion should be inspected using visual inspection internally if possible or by using radiography. Scanning of the areas with UT is also a good technique and should be used if the line is larger than NPS 12.

5.6 CMLs

5.6.1 General

CMLs are specific areas along the piping circuit where inspections are conducted. The nature of the CML varies according to its location in the piping system. The allocation of CMLs shall consider the potential for service-specific damage mechanisms; e.g. localized corrosion, as described in API 574 and API 571. Examples of different conditions to be monitored at CMLs include wall thickness, stress cracking, CUI and high temperature hydrogen attack.

5.6.2 CML Monitoring

Each piping system shall be monitored at appropriately placed CMLs. Piping circuits subject to higher corrosion rates or localized corrosion will normally have more CMLs and be monitored more frequently. The minimum measured thickness at a CML can be located by ultrasonic scanning or profile radiography. Electromagnetic techniques also can be used to identify thin areas that may then be measured by UT or radiography. When accomplished with UT, scanning consists of taking several thickness measurements at the CML searching for localized thinning. The thinnest reading or an average of several measurement readings taken within the area of a examination point shall be recorded and used to calculate corrosion rates, remaining life, and the next inspection date in accordance with Section 7.

Where appropriate, thickness measurements should include measurements at each of the four quadrants on pipe and fittings, with special attention to the inside and outside radius of elbows and tees where corrosion/erosion could increase corrosion rates. As a minimum, the thinnest reading or an average of several measurements at each recording point at a CML shall be recorded. The rate of corrosion/damage shall be determined from successive measurements and the next inspection interval appropriately established. Corrosion rates, the remaining life and next inspection intervals should be calculated to determine the limiting component of each piping circuit. For systemized/circuitized piping, the corrosion rates and remaining life may be determined statistically per paragraph 6.5.3.

CMLs should be established for areas with continuing CUI, corrosion at SAI interfaces, immediately upstream and downstream of piping material changes (e.g. spec breaks) or other locations of potential localized corrosion as well as for general, uniform corrosion.

CMLs should be marked on inspection drawings. The piping system may also be marked to allow repetitive measurements at the same locations. This recording procedure provides data for more accurate corrosion rate determination. The rate of corrosion/damage shall be determined from successive measurements and the next inspection interval appropriately established based on the remaining life or RBI analysis.

5.6.3 CML Allocation

CMLs should be distributed appropriately throughout each piping circuit. CMLs may be eliminated or the number reduced under certain circumstances when the expected damage mechanism will not result in a wall loss or other forms of deterioration, such as olefin plant cold side piping, anhydrous ammonia piping, clean noncorrosive hydrocarbon product, or high-alloy piping for product purity. In circumstances where CMLs will be substantially reduced or eliminated, a corrosion specialist should be consulted.

In selecting or adjusting the number and locations of CMLs, the inspector should take into account the patterns of corrosion that would be expected and have been experienced in the process unit. A decision on the type, number and location of the CMLs should consider results from previous inspections, the patterns of corrosion and damage that are expected and the potential consequence of loss of containment. CMLs should be distributed appropriately over the piping system to provide adequate monitoring coverage of major components and nozzles. Thickness measurements at CMLs are intended to establish general and localized corrosion rates in different sections of the piping circuits. A minimal number of CMLs are acceptable when the established corrosion rate is low and the corrosion is not localized.

A number of corrosive processes common to refining and petrochemical units are relatively uniform in nature, resulting in a fairly constant rate of pipe wall reduction independent of location within the piping circuit, either axially or circumferentially. Examples of such corrosion phenomena include sulfidation corrosion (provided that it is a uniform liquid phase with no naphthenic acid and the piping circuit does not contain low silicon CS, see 5.12 and API 939-C) and sour water corrosion (provided velocities are not so high as to cause local corrosion/erosion of elbows, tees, and other similar items). In these situations, the number of CMLs required to monitor a circuit will be fewer than those required to monitor circuits subject to more localized metal loss. In theory, a circuit subject to perfectly uniform corrosion could be adequately monitored with a single CML. In reality, corrosion is seldom truly uniform and in fact may be quite localized, so additional CMLs may be required. Inspectors must use their knowledge (and that of others) of the process unit to optimize the CML allocation for each circuit, balancing the effort of collecting the data with the benefits provided by the data. Where there is adequate historical thickness data for a circuit and data has been validated to ensure it is representative for the expected corrosion environment, a statistical analysis may be useful to help determine the number of inspection points needed to establish the desired confidence in the calculated circuit average rate, limiting thickness and/or remaining life.

More CMLs should be selected for corrosive piping systems with any of the following characteristics:

- a) higher potential for creating a safety or environmental emergency in the event of a leak;
- b) higher expected or experienced corrosion rates;
- c) higher potential for localized corrosion;
- d) more complexity in terms of fittings, branches, deadlegs, injection points, and other similar items;
- e) higher potential for CUI;
- f) higher corrosion rate (or thickness) variability;
- g) higher short/long rate (or maximum / average) ratios;
- h) higher degree of process variability (process parameters that will affect localized corrosion);

- i) circuits with corrosion environments which have experienced unexpected failures in the facility or elsewhere in the industry.

Fewer CMLs can be selected for piping systems with any of the following three characteristics:

- a) low potential for creating a safety or environmental emergency in the event of a leak;
- b) relatively noncorrosive piping systems;
- c) long, straight-run piping systems.

CMLs can be eliminated for piping systems with any of the following characteristics:

- a) extremely low potential for creating a safety or environmental emergency in the event of a leak;
- b) noncorrosive systems, as demonstrated by history or similar service; and
- c) systems not subject to changes that could cause corrosion as demonstrated by history and/or periodic reviews.

Every CML should have at least one or more examination points identified. Examples include:

- a) locations marked on un-insulated pipe using paint stencils, metal stencils, or stickers;
- b) holes cut in the insulation and plugged with covers;
- c) temporary insulation covers for fittings nozzles, etc.;
- d) isometrics or documents showing CMLs;
- e) radio frequency identification devices (RFID);
- f) computerized monitoring buttons (CMB).

Careful identification of CMLs and examination points are necessary to enhance the accuracy and repeatability of the data.

Corrosion specialists should be consulted about the appropriate placement and number of CMLs for piping systems susceptible to localized corrosion or cracking, or in circumstances where CMLs will be substantially reduced or eliminated.

5.7 Condition Monitoring Methods

5.7.1 UT and RT

ASME *BPVC* Section V, Article 23, and Section SE-797 provide guidance for performing ultrasonic thickness measurements. Radiographic profile techniques are preferred for pipe diameters of NPS 1 and smaller. PRT is preferred for SBP where digital ultrasonic thickness gauging (DUT) are not very reliable. PRT is very often the technique of choice on NPS 8 and under when localized corrosion is suspected. Ultrasonic thickness measurements taken on small bore pipe may require specialized equipment (e.g. miniature transducers and/or curved shoes as well as diameter-specific calibration blocks); however, Profile RT is typically the method of choice for thickness measurements on small bore piping. Radiographic profile techniques may be used for measuring thicknesses, particularly in insulated systems or where nonuniform or localized corrosion is suspected. Where practical, UT can then be used to obtain the actual thickness of the areas to be recorded. Following ultrasonic readings at CMLs, proper repair of insulation and insulation weather coating is recommended to reduce the potential for CUI.

Radiographic profile techniques, which do not require removing insulation, may be considered as an alternative. See API 574 for additional information on thickness monitoring methods for piping. When corrosion in a piping system is nonuniform or the remaining thickness is approaching the minimum required thickness, additional thickness measuring may be required. Radiography and ultrasonic scanning are the preferred methods in such cases.

When ultrasonic measurements are taken above 150 °F (65 °C), instruments, couplants, and procedures should be used that will result in accurate measurements at the higher temperatures. If the procedure does not compensate for higher temperatures, measurements should be adjusted by the appropriate temperature correction factor.

Inspectors should be aware of possible sources of measurement inaccuracies and make every effort to eliminate their occurrence. As a general rule, each of the NDE techniques will have practical limits with respect to accuracy. Factors that can contribute to reduced accuracy of ultrasonic measurements include the following:

- a) improper instrument calibration;
- b) external coatings or scale;
- c) significant surface roughness;
- d) transducer placement and orientation (e.g., curved surface placement, pitch/catch probe orientation);
- e) subsurface material flaws, such as laminations;
- f) temperature effects [at temperatures above 150 °F (65 °C)];
- g) improper resolution on the detector screens;
- h) thicknesses of less than $\frac{1}{8}$ in. (3.2 mm) for typical digital thickness gauges;
- i) improper coupling of probe to the surface (too much or too little couplant).

In addition, it must be kept in mind that the pattern of corrosion can be nonuniform. For corrosion rate determinations to be valid, it is important that measurements on the thinnest point be repeated as closely as possible to the same location. Alternatively, the minimum reading or an average of several readings at a examination point may be considered.

When piping systems are out of service, thickness measurements may be taken through openings using calipers. Calipers are useful in determining approximate thicknesses of castings, forgings, and valve bodies, as well as pit depth approximations from CUI on pipe.

Pit depth measuring devices also may be used to determine the depth of localized metal loss.

5.7.2 Other NDE Techniques for Piping Systems

In addition to thickness monitoring, other examination techniques may be appropriate to identify or monitor for other specific types of damage mechanisms. In selecting the technique(s) to use during piping inspection, the possible types of damage for each piping circuit should be taken into consideration. The inspector should consult with a corrosion specialist or an engineer to help define the type of damage, the NDE technique and extent of examination. API 571 and API 577 also contains some general guidance on inspection techniques that are appropriate for different damage mechanisms. Examples of NDE techniques that may be of use include the following.

- a) Magnetic particle examination for cracks and other linear discontinuities that extend to the surface of the material in ferromagnetic materials. ASME *BPVC*, Section V, Article 7, provides guidance on performing MT examination.

- b) Liquid penetrant examination for disclosing cracks, porosity, or pin holes that extend to the surface of the material and for outlining other surface imperfections, especially in nonmagnetic materials. ASME *BPVC*, Section V, Article 6, provides guidance on performing PT examination.
- c) RT for detecting internal imperfections such as porosity, weld slag inclusions, cracks, and thickness of components. ASME *BPVC*, Section V, Article 2, provides guidance on performing RT.
- d) Ultrasonic flaw detection for detecting internal and surface breaking cracks and other elongated discontinuities. ASME *BPVC*, Section V, Article 4, Article 5, and Article 23, provide guidance on performing UT.
- e) Alternating current flux leakage examination technique for detecting surface-breaking cracks and elongated discontinuities.
- f) Eddy current examination for detecting localized metal loss, cracks, and elongated discontinuities. ASME *BPVC*, Section V, Article 8, provides guidance on performing eddy current examination.
- g) Field metallographic replication for identifying metallurgical changes.
- h) Acoustic emission examination for detecting structurally significant defects. ASME *BPVC*, Section V, Article 11 and Article 12, provides guidance on performing acoustic emission examination.
- i) Thermography for determining temperature of components, blockages, debris/sediment levels, and flow verification.
- j) Leak testing for detecting through-thickness defects. ASME *BPVC* Section V, Article 10, provides guidance on performing leak testing.
- k) Guided wave examination for the detection of metal loss.

5.7.3 Surface Preparation for NDE

Adequate surface preparation is important for proper visual examination and for the satisfactory application of most examination methods, such as those mentioned above. The type of surface preparation required depends on the individual circumstances and NDE technique, but surface preparations such as wire brushing, blasting, chipping, grinding, or a combination of these preparations may be required.

Advice from NDE specialists may be needed in order to select and apply the proper surface preparation for each individual NDE technique.

5.7.4 UT Angle Beam Examiners

The owner/user shall specify industry-qualified UT angle beam examiners when the owner/user requires the following:

- a) detection of interior surface (ID) breaking flaws when inspecting from the external surface (OD); or
- b) detection, characterization, and/or through-wall sizing of defects.

Application examples for the use of industry-qualified UT angle beam examiners include detecting and sizing planer flaws from the external surface and collecting data for Fitness-For-Service evaluations.

5.8 Corrosion Under Insulation Inspection

Inspection for CUI shall be considered for externally-insulated carbon and low alloy piping operating between 10 °F (–12 °C) and 350 °F (175 °C). CUI inspections may be conducted as part of the external inspection. If CUI damage is found during spot checks, the inspector should inspect other susceptible areas on the piping. API 583 on CUI has much more detailed information on CUI and should be used in conjunction with piping CUI inspection programs.

Although external insulation may appear to be in good condition, CUI damage may still be occurring. Non-intrusive techniques such as real time radiography can help to determine if any scale is present behind the insulation without removal. Other techniques such as profile radiography, Pulsed Eddy Current and Guided Wave Examination can help to locate damage. Removal of scale on live equipment and removal of insulation where leaks are suspected can pose a significant safety risk. CUI damage is often quite insidious in that it can occur in areas where it seems unlikely.

Considerations for insulation removal include but are not limited to:

- a) history of CUI for the specific piping system or comparable piping systems;
- b) visual condition of the external covering and insulation; rust stains, biological growth and bulged weather jacketing;
- c) evidence of fluid leakage (e.g. drips or vapors);
- d) whether the piping systems are in intermittent service;
- e) condition/age of the external coating, if known;
- f) evidence of areas with wet insulation;
- g) potential for the type of insulation to absorb/hold more water (e.g. calcium silicate versus cellular glass);
- h) low points of sagging lines;
- i) bottom of vertical pipe;
- j) proximity to equipment that could increase the local humidity, (e.g. cooling towers);
- k) areas where temperature regimes are moving into and out of the CUI temperature range.

5.9 Mixing Point Inspection

Mixing points are locations in piping systems where two or more different streams meet. The difference in streams may be composition, temperature or any other parameter that may contribute to deterioration, accelerated or localized corrosion, and/or thermal fatigue during normal or abnormal operating conditions.

All potentially problematic (subject to corrosion or cracking) mixing points should be identified and reviewed to determine if these areas have an increased susceptibility, or rate of degradation from specific damage mechanisms as compared to the parent/contributing piping streams. Mixing points identified as such, may be treated as separate inspection circuits, and these areas may need to be inspected differently, using special techniques, different scope, and at more frequent intervals when compared to the inspection plan for the parent/contributing piping stream(s). It should be recognized that after review, some mixing points may not require any special emphasis inspection techniques or intervals.

Given the wide variation of mixing point designs and operation parameters, it is beyond the scope of this Code to provide specific inspection recommendations for mixing point circuits. It is anticipated that defining those inspection recommendations will require careful review in consideration of mix point design (configuration and metallurgy), stream flow regime, composition and temperature differences, along with expected damage mechanism susceptibilities, and rates of degradation. Refer to API 574 for additional information on process mixing points.

Similar to injection point circuits, the preferred methods of inspecting mixing points include; radiography and ultrasonics (straight beam and/or angle beam) to determine the minimum measured thickness and/or the presence of other susceptible damage mechanisms (e.g. thermal fatigue cracking and pitting) at each CML.

Changes to mixing points, including but not limited to changes in: flow regime, stream composition or characteristics, or components of construction and their orientation, should be identified and reviewed to determine what, if any changes to the inspection plan may be required as a result.

See NACE SP 0114, *Refinery Injection and Process Mixing Points* for additional information.

5.10 Injection Point Inspection

Injection points are sometimes subject to accelerated or localized corrosion from normal or abnormal operating conditions. Those that are susceptible should be treated as separate inspection circuits, and these areas need to be inspected thoroughly on a regular schedule.

When designating an injection point circuit for the purposes of inspection, the recommended upstream limit of the injection point circuit is a minimum of 12 in. (300 mm) or three pipe diameters upstream of the injection point, whichever is greater. The recommended downstream limit of the injection point circuit is the second change in flow direction past the injection point, or 25 ft (7.6 m) beyond the first change in flow direction, whichever is less. In some cases, it may be more appropriate to extend this circuit to the next piece of pressure equipment, as shown in Figure 1.

The selection of condition monitoring locations (CMLs) within injection point circuits subject to localized corrosion should be in accordance with the following guidelines:

- a) establish CMLs on appropriate fittings within the injection point circuit,
- b) establish CMLs on the pipe wall at the location of expected pipe wall impingement of injected fluid,
- c) establish CMLs at intermediate locations along the longer straight piping within the injection point circuit may be required,
- d) establish CMLs at both the upstream and downstream limits of the injection point circuit.

The preferred methods of inspecting injection points are radiography and/or UT scanning or closely spaced UT grid inspection, as appropriate, to establish the minimum measured thickness at each CML. Close grid ultrasonic measurements or scanning may be used, as long as temperatures are appropriate.

For some applications, it is beneficial to remove piping spools to facilitate a visual inspection of the inside surface. However, thickness measurements will still be required to determine the remaining thickness.

During periodic scheduled inspections, more extensive inspection should be applied to an area beginning 12 in. (300 mm) upstream of the injection nozzle and continuing for at least ten pipe diameters downstream of the injection point. Additionally, measure and record the thickness at all CMLs within the injection point circuit. The potential for localized corrosion can occur at the junction where the injection point enters into the primary pipe. The use of profile radiography at the junction and UT manual scanning of the primary pipe (surrounding and downstream of the junction) is recommended

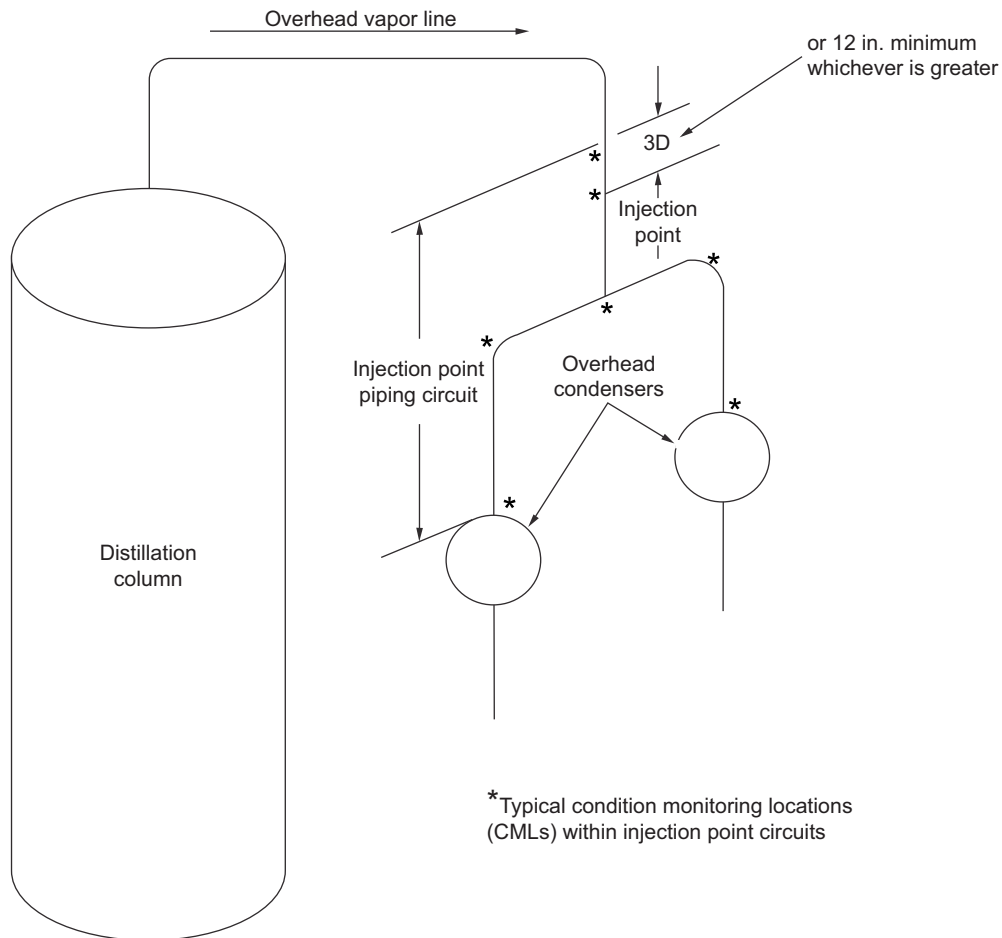

Figure 1—Typical Injection Point Piping Circuit

The hardware used to inject the fluid into the process stream is important for proper mixing of the streams. Most configurations use either an injection nozzle or quill that project into the process stream. These injection nozzles (or quills) should be periodically inspected to assure they are still intact, and are in the correct orientation (i.e. nozzle pointed upstream if that is the intended design). Use of radiography for periodic inspections of the injection nozzle or quill is recommended for this purpose.

5.11 Pressure Testing of Piping Systems

5.11.1 General

Pressure tests are not normally conducted as part of a routine inspection (see 8.2.8 for pressure testing requirements for repairs, alterations, and re-rating). Exceptions to this include requirements of the Coast Guard for over water piping and requirements of local jurisdictions, after welded alterations, buried piping or when specified by the inspector or piping engineer. When they are conducted, pressure tests shall be performed in accordance with the requirements of ASME B31.3. Additional considerations for pressure testing are provided in API 574, API 579-1/ASME FFS-1, and ASME PCC-2 Article 5.1. Service tests and/or lower pressure tests, which are used only for tightness of piping systems, may be conducted at pressures designated by the owner/user.

Pressure tests are typically performed on an entire piping circuit. However, where practical, pressure tests of individual components/sections can be performed in lieu of entire circuit (e.g. a replacement section of piping). An

engineer should be consulted when a pressure test of piping components/sections is to be performed (including use of isolation devices) to ensure it is suitable for the intended purpose.

When a pressure test is required, it shall be conducted after any heat treatment.

Before applying a hydrostatic test, the supporting structures and foundation design should be reviewed by an engineer to ensure that they are suitable for the hydrostatic load.

NOTE The owner/user is cautioned to avoid exceeding 90 % of the specified minimum yield strength (SMYS) for the material at test temperature and especially for equipment used in elevated temperature service.

5.11.2 Test Fluid

The test fluid should be water unless there is the possibility of damage due to freezing or other adverse effects of water on the piping system or the process (e.g. process incompatibility with water) or unless the test water will become contaminated and its disposal will present environmental problems. In either case, another suitable nontoxic liquid may be used. If the liquid is flammable, its flash point shall be at least 120 °F (49 °C) or greater, and consideration shall be given to the effect of the test environment on the test fluid.

Piping fabricated of or having components of austenitic stainless steel should be hydrotested with a solution made up of potable water (see note), de-ionized/de-mineralized water or steam condensate having a total chloride concentration (not free chlorine concentration) of less than 50 ppm.

NOTE Potable water in this context follows U.S. practice, with 250 parts per million maximum chloride, sanitized with chlorine or ozone.

For sensitized austenitic stainless steel piping subject to polythionic stress corrosion cracking, consideration should be given to using an alkaline-water solution for pressure testing where accelerated corrosion of the sensitized region may be an issue (see NACE RP 0170).

If a pressure test is to be maintained for a period of time and the test fluid in the system is subject to thermal expansion, precautions shall be taken to avoid pressure build up beyond that specified.

After testing is completed, the piping should be thoroughly drained (all high-point vents should be open during draining), air blown, or otherwise dried. If potable water is not available or if immediate draining and drying is not possible, water having a very low chloride level, higher pH (>10), and inhibitor addition may be considered to reduce the risk of pitting and microbiologically induced corrosion.

5.11.3 Pneumatic Pressure Tests

A pneumatic (or hydro pneumatic) pressure test may be used when it is impracticable to hydrostatically test due to temperature, structural, or process limitations. However, the potential risks to personnel and property of pneumatic testing shall be considered when carrying out such a test. As a minimum, the inspection precautions contained in ASME B31.3 shall be applied in any pneumatic testing. See ASME PCC-2 for precautions on pneumatic pressure testing.

5.11.4 Test Temperature and Brittle Fracture Considerations

At ambient temperatures, carbon, low-alloy, and other steels, including high alloy steels embrittled by service exposure, may be susceptible to brittle failure. A number of failures have been attributed to brittle fracture of steels that were exposed to temperatures below their transition temperature and to pressures greater than 25 % of the required hydrostatic test pressure or 8 ksi of stress, whichever is less. Most brittle fractures, however, have occurred on the first application of a high stress level (the first hydro test or overload). The potential for a brittle failure shall be evaluated by an engineer prior to hydrostatic testing or especially prior to pneumatic testing because of the higher

potential energy involved. Special attention should be given when testing low-alloy steels, especially 2¹/₄Cr-1Mo, because they may be prone to temper embrittlement.

To minimize the risk of brittle fracture during a pressure test, the metal temperature should be maintained at least 30 °F (17 °C) above the MDMT for piping that is more than 2 in. (5 cm) thick, and 10 °F (6 °C) above the MDMT for piping that have a thickness of 2 in. (5 cm) or less. The test temperature need not exceed 120 °F (50 °C) unless there is information on the brittle characteristics of the piping construction material indicating a higher test temperature is needed.

5.11.5 Precautions and Procedures

During a pressure test, where the test pressure will exceed the set pressure of the pressure relieving device on a piping system, the pressure relieving device(s) should be removed or blanked for the duration of the test. As an alternative, each valve disk shall be held down by a suitably designed test clamp. The application of an additional load to the valve spring by turning the adjusting screw is prohibited. Other appurtenances that are incapable of withstanding the test pressure, such as gage glasses, pressure gages, expansion joints, and rupture disks, should be removed or blanked. Lines containing expansion joints that cannot be removed or isolated may be tested at a reduced pressure in accordance with the principles of ASME B31.3. If block valves are used to isolate a piping system for a pressure test, caution should be used to not exceed the permissible seat pressure as described in ASME B16.34 or applicable valve manufacturer data.

Upon completion of the pressure test, pressure relieving devices of the proper settings and other appurtenances removed or made inoperable during the pressure test shall be reinstalled or reactivated.

Before applying a pressure test, appropriate precautions and procedures should be taken into account to assure the safety of personnel involved with the pressure test. A close visual inspection of piping components should not be performed until the equipment pressure is at or below the MAWP. This review is especially important for in-service piping.

5.11.6 Pressure Testing Alternatives

Appropriate NDE shall be specified and conducted when a pressure test is not performed after a major repair or alteration. Substituting NDE procedures for a pressure test after an alteration is allowed only after the engineer and inspector have approved the substitution.

For cases where UT is used in lieu of a pressure test, the owner/user shall specify industry-qualified UT angle beam examiners. ASME B31 Code Case 179 may be used in lieu of RT for B31.1 piping welds, and alternative UT acceptance criteria provided in B31 Code Case 181 may be used in lieu of those described in para. 344.6.2 of ASME B31.3, as applicable, for closure welds that have not been pressure tested and for welding repairs identified by the engineer or inspector.

5.12 Material Verification and Traceability

The owner/user shall assess the need for and extent of application of a material verification program consistent with API 578 addressing inadvertent material substitution in existing alloy piping systems. A material verification program consistent with API 578 may include procedures for prioritization and risk ranking of piping circuits. That assessment may lead to retroactive PMI examination, as described in API 578, to confirm that the installed materials are consistent with the intended service. Components identified during this verification that do not meet acceptance criteria of the PMI examination program (such as in API 578) would be targeted for replacement. The owner/user and authorized piping inspector, in consultation with a corrosion specialist, shall establish a schedule for replacement of those components. The authorized inspector shall use periodic NDE, as necessary, on the identified components until the replacement.

In lines in older process units operating above 500 °F (260 °C) and subject to sulfidation corrosion, carbon steel piping containing less than 0.1 wt % silicon can corrode at significantly higher rates than higher silicon carbon steels (modern “silicon-killed” process). For piping systems / circuits that have been identified in sulfidation corrosion service that may contain older low silicon carbon steels, consideration should be given to conducting inspection of each piping segment in order to identify the worst case corrosion rate / limiting component.

After about 1985 to 1990, most purchased pipe became double stamped, and hence the low-silicon issue diminished for piping purchased and installed after that time frame. Inspection techniques that can be useful for finding susceptible components under insulation include real time radiography, GWT, and PEC. Inspection plans for sulfidation corrosion should be in accordance with API 939-C.

During repairs or alterations to alloy material piping systems, where the alloy material is required to maintain pressure containment, the inspector shall verify that the installation of new materials is consistent with the selected or specified construction materials. This material verification program should be consistent with API 578. Using risk assessment procedures, the owner/user can make this assessment by 100 % verification, PMI examination in certain critical situations, or by sampling a percentage of the materials. PMI examination can be accomplished by the inspector or the examiner with the use of suitable methods as described in API 578.

If a piping system component should fail because an incorrect material was inadvertently substituted for the proper piping material, the inspector shall consider the need for further verification of existing piping materials. The extent of further verification will depend upon circumstances such as the consequences of failure and the probability of further material errors.

5.13 Inspection of Valves

Normally, thickness measurements are not routinely taken on valves in piping circuits. The body of a valve is normally thicker than other piping components for design reasons. However, when valves are dismantled for servicing and repair, the shop personnel should visually examine the valve components for any unusual corrosion patterns or thinning and, when noted, report that information to the inspector. Bodies of valves that are exposed to significant temperature cycling (for example, catalytic reforming unit regeneration and steam cleaning) should be examined periodically for thermal fatigue cracking.

If gate valves are known to be or are suspected of being exposed to severe or unusual corrosion-erosion, thickness readings should be conducted on the body between the seats, since this is an area of high turbulence and high stress.

Control valves or other throttling valves, particularly in high-pressure drop and slurry services, can be susceptible to localized corrosion/erosion of the body downstream of the orifice. If such metal loss is suspected, the valve should be removed from the line for internal inspection. The inside of the downstream mating flange and piping also should be inspected for local metal loss.

When valve body and/or closure pressure tests are performed after servicing, they should be conducted in accordance with API 598. Critical check valves shall be adequately inspected or tested to provide greater assurance that they will prevent flow reversals. An example of a critical check valve may be the check valve located on the outlet of a multistage, high head hydro processing charge pump. Failure of such a check valve to operate correctly could result in over pressuring the piping during a flow reversal. The normal visual inspection method should include the following items.

- a) Checking to insure that the flapper is free to move, as required, without looseness beyond tolerance due to wear.
- b) The flapper stop should not have wear beyond tolerance. This will minimize the likelihood that the flapper will move past the top dead central position and remain in an open position when the check valve is mounted in a vertical position.

- c) The flapper nut should be secured to the flapper bolt to avoid backing off in service.

Leak checks of critical check valves are normally not required, but may be considered for special circumstances.

5.14 In-service Inspection of Welds

Inspection for piping weld quality is normally accomplished as a part of the requirements for new construction, repairs, or alterations. However, welds are often inspected for corrosion as part of a radiographic profile inspection or as part of internal inspection. When preferential weld corrosion is noted, additional welds in the same circuit or system should be examined for corrosion. API 577 provides additional guidance on weld inspection.

Due to the different capabilities and characteristics of various NDE methods to find flaws, using an NDE method that is different from the one employed during original fabrication may reveal pre-existing flaws that were not caused by in-service exposure (e.g., applying UT and MT for in-service inspection when only RT was applied during fabrication). For this reason, it is often a good practice to specify the types of NDE during original fabrication that the owner/user plans to apply during in-service inspections.

On occasion, radiographic profile examinations of welds that have been in-service may reveal a flaw in the weld. If crack-like imperfections are detected while the piping system is in operation, further inspection with weld quality radiography and/or UT should be used to assess the magnitude of the imperfection. Additionally, the inspector should make an effort to determine whether the crack-like imperfections are from original weld fabrication or may be from an environmental cracking mechanism.

Crack-like flaws and environmental cracking shall be assessed by an engineer in accordance with API 579-1/ASME FFS-1 and/or corrosion specialist. Preferential weld corrosion shall be assessed by the inspector. Issues to consider when assessing the quality of existing welds include the following:

- a) original fabrication inspection method and acceptance criteria;
- b) extent, magnitude, and orientation of imperfections;
- c) length of time in service;
- d) operating versus design conditions;
- e) presence of secondary piping stresses (residual and thermal);
- f) potential for fatigue loads (mechanical and thermal);
- g) primary or secondary piping system;
- h) potential for impact or transient loads;
- i) potential for environmental cracking;
- j) repair and heat treatment history;
- k) dissimilar metal welds such as ferritic-to-austenitic and alloy 400 to carbon steel welds;
- l) weld hardness.

For in-service piping weldments, it may not be appropriate to use the original construction code radiography acceptance criteria for weld quality in ASME B31.3. The B31.3 acceptance criteria are intended to apply to new construction on a sampling of welds, not just the welds examined, in order to assess the probable quality of all welds

(or welders) in the system. Some welds may exist that will not meet these criteria but will still perform satisfactorily in-service after being hydrostatically tested. This is especially true on small branch connections that are normally not examined during new construction.

The owner/user shall specify industry-qualified UT angle beam examiners when the owner/user requires either of the following items.

- a) Detection of interior surface (ID) breaking planar flaws when inspecting from the external surface (OD).
- b) Where detection, characterization, and/or through-wall sizing is required of planar defects. Application examples for the use of such industry-qualified UT angle beam examiners include obtaining flaw dimensions for Fitness-For-Service assessment and monitoring of known flaws.

5.15 Inspection of Flanged Joints

Flanged joints should be examined for evidence of leakage, such as stains, deposits, or drips. Process leaks onto flange fasteners and valve bonnet fasteners may result in corrosion or environmental cracking. This examination should include those flanges enclosed with flange or splash-and-spray guards. Flanged joints that have been clamped and pumped with sealant should be checked for leakage at the bolts. Fasteners subjected to such leakage may corrode or crack (e.g. caustic cracking). If repumping is contemplated, affected fasteners should be renewed first.

Accessible flange faces should be examined for distortion and to determine the condition of gasket-seating surfaces. If flanges are significantly bent or distorted, their markings and thicknesses should be checked against engineering requirements before taking corrective action.

Flange fasteners should be examined visually for corrosion and thread engagement. Fasteners should be fully engaged. Any fastener failing to do so is considered acceptably engaged if the lack of complete engagement is not more than one thread. The markings on a representative sample of newly installed fasteners and gaskets should be examined to determine whether they meet the material specification. The markings are identified in the applicable ASME and ASTM standards. Questionable fasteners should be verified or renewed.

Additional guidance on the inspection of flanged joints can be found in ASME PCC-1.

6 Interval/Frequency and Extent of Inspection

6.1 General

To ensure equipment integrity, all piping systems and pressure-relieving devices shall be inspected at the intervals/frequencies provided in this section. Scheduled inspections shall be conducted on or before their due date or be considered overdue for inspection. Alternatively, an inspection due date may be determined through a risk assessment in accordance with API 580. This due date may exceed the typical half-life interval used in a more conventional analysis. Note not all RBI analysis produce an inspection interval, some generate an inspection due date based on acceptable risk criteria. See 7.13 for more information and requirements on overdue inspections and deferrals.

The appropriate inspection shall provide the information necessary to determine that all of the essential sections or components of the equipment are safe to operate until the next scheduled inspection. The risks associated with operational shutdown and start-up and the possibility of increased corrosion due to exposure of equipment surfaces to air and moisture during shutdown should be evaluated when an internal inspection is being planned.

This Code is based upon monitoring a representative sampling of inspection locations on selected piping with specific intent to reveal a reasonably accurate assessment of the condition of the piping.

6.2 Inspection During Installation and Service Changes

6.2.1 Piping Installation

Piping shall be inspected in accordance with code of construction requirements at the time of installation. The purpose of installation inspection is to verify that the piping is clean and safe for operation, and to initiate plant inspection records for the piping systems. The minimum installation inspection should include the following items:

- a) verifying that piping is installed correctly, the correct metallurgy is installed, supports are adequate and secured, exterior attachments such as supports, shoes, hangers are secured, insulation is properly installed, flanged and other mechanical connections are properly assembled and the piping is clean and dry;
- b) verifying the pressure-relieving devices satisfy design requirements (correct device and correct set pressure) and are properly installed.

This installation inspection should document base-line thickness measurements to be used as initial thickness readings for corrosion rate calculations in lieu of nominal and minimum design thickness data in specifications, and design datasheets/drawings. This will also facilitate the creation of an accurate corrosion rate calculation after the first in-service thickness measurements are recorded.

6.2.2 Piping Service Change

If the service conditions of the piping system are changed, i.e. will exceed the current operating envelope (e.g., process contents, maximum operating pressure, and the maximum and minimum operating temperature), inspection intervals shall be established for the new service conditions, including the review of applicable pressure relieving device settings.

If both the ownership and the location of the piping are changed, the piping shall be inspected before it is reused. Also, the allowable service conditions and the inspection interval shall be established for the new service.

6.3 Piping Inspection Planning

6.3.1 General

The frequency and extent of inspection on piping circuits whether above or below ground depend on the forms of degradation that can affect the piping and consequence of a piping failure. The various forms of degradation that can affect process piping circuits are described in API 571 in more detail. A simplified classification of piping based on the consequence of failure is defined in 6.3.4. As described in 5.3, inspection strategy based on probability and consequence of failure is referred to as RBI.

The simplified piping classification scheme in 6.3.4 is based on the consequence of a failure. The classification is used to establish frequency and extent of inspection. The owner/user may devise a more extensive classification scheme that more accurately assesses consequence for certain piping circuits. The consequence assessment would consider the potential for explosion, fire, toxicity, environmental impact, and other potential effects associated with a failure. Reference API 580 Assessing Consequence of Failure guidelines and requirements.

After an effective assessment is conducted, the results can be used to establish a piping circuit inspection strategy and define the appropriate inspection plan per 5.2

6.3.2 Setting Inspection Intervals with RBI

An RBI assessment conducted in accordance with API 580 may be used to determine the inspection intervals or next inspection due date and extent of inspection.

6.3.3 Setting Inspection Intervals Without the Use of RBI

If RBI is not being used, the interval between piping inspections shall be established and maintained by using the following criteria:

- a) the corrosion rate and remaining life calculations;
- b) the piping service classification (see 6.3.4);
- c) the applicable jurisdictional requirements;
- d) and the judgment of the inspector, the piping engineer, the piping engineer supervisor, or a materials specialist, based on operating conditions, previous inspection history, current inspection results, and conditions that may warrant supplemental inspections covered in 5.5.

The owner/user or the inspector shall establish inspection intervals for thickness measurements and external visual inspections and, where applicable, for internal and supplemental inspections.

For Class 1, 2, and 3 piping, the period between thickness measurements for CMLs or circuits should not exceed one-half the remaining life or the maximum intervals recommended in Table 1, whichever is less. Whenever the remaining life is less than four years, the inspection interval may be the full remaining life up to a maximum of two years. The interval is established by the inspector or piping engineer in accordance with the owner/user’s QA system.

Table 1—Recommended Maximum Inspection Intervals

Type of Circuit	Thickness Measurements	Visual External
Class 1	5 years	5 years
Class 2	10 years	5 years
Class 3	10 years	10 years
Class 4	Optional	Optional
Injection points ^a	3 years	By class
Soil to Air Interfaces ^b	—	By class

NOTE Thickness measurements apply to systems for which CMLs have been established in accordance with 5.6.

^a Inspection intervals or due dates for potentially corrosive injection can also be established by a valid RBI analysis in accordance with API 580.

^b See API 574 for more information on SAI interfaces.

Maximum intervals for Class 4 piping are left to the determination of the owner/user depending upon reliability and business needs.

For piping that is in non-continuous service, the interval between thickness measurements may be based on the number of years of actual service (piping in operation) instead of calendar years, provided that when idled, the piping is:

- a) isolated from the process fluids, and
- b) not exposed to corrosive internal environments (e.g. inert gas purged or filled with noncorrosive hydrocarbons). Piping that is in non-continuous service and not adequately protected from corrosive environments may experience increased internal corrosion while idle. The corrosion rates should be carefully reviewed before setting the intervals.

The inspection interval shall be reviewed and adjusted as necessary after each inspection or significant change in operating conditions and/or inspection results. General corrosion, localized corrosion, pitting, environmental cracking, and other applicable forms of deterioration mentioned in 5.5 and API 571 shall be considered when establishing the various inspection intervals.

6.3.4 Piping Service Classes

6.3.4.1 General

All process piping systems shall be categorized into different piping classes except for piping that has been planned on the basis of RBI. Such a classification system allows extra inspection efforts to be focused on piping systems that may have the highest potential consequences if failure or loss of containment should occur. In general, the higher classified systems require more extensive inspection at shorter intervals in order to affirm their integrity for continued safe operation. Classifications should be based on potential safety and environmental effects should a leak occur. When pipe service conditions change, pipe classifications and inspection plans should be reviewed and updated as necessary to reflect the changed operating conditions; e.g. a hydrocarbon service temperature increase that might change from “slowly vaporizing during a release” to “rapidly vaporizing during a release.”

Owner/users shall maintain a record of process piping fluids handled, including their classifications. NFPA 704 provides information that may be helpful in classifying piping systems according to the potential hazards of the process fluids they contain.

NOTE The operating temperature of a hydrocarbon stream relative to its flash point, boiling point and auto-ignition temperature is a significant factor in defining potential consequence of a release. Operating temperature of hydrocarbon piping systems should be considered when assigning piping service class. For example, on-site ambient temperature gasoline is Class 2 since it is below the boiling point but above the flash point of gasoline. However, on-site gasoline at 550 °F should be Class 1 since auto-ignition can occur.

The four classes listed below in 6.3.4.2 through 6.3.4.5 are recommended.

6.3.4.2 Class 1

Services with the highest potential of resulting in an immediate emergency if a leak were to occur are in Class 1. Such an emergency may be safety or environmental in nature. Examples of Class 1 piping include, but are not necessarily limited to, those containing the following.

- a) Flammable services that can auto-refrigerate and lead to brittle fracture.
- b) Pressurized services that can rapidly vaporize during release, creating vapors that can collect and form an explosive mixture, such as C2, C3, and C4 streams. Fluids that can rapidly vaporize are those with atmospheric boiling temperatures below 50 °F (10 °C) or where the atmospheric boiling point is below the operating temperature (typically a concern with high-temperature services).
- c) Hydrogen sulfide (greater than 3 % weight) in a gaseous stream.
- d) Anhydrous hydrogen chloride.
- e) Hydrofluoric acid in main and trace acid services per API RP 751.
- f) Piping over or adjacent to water and piping over public thoroughways (refer to national or local regulations e.g. Department of Transportation and Coast Guard for inspection of over water piping).
- g) Flammable services operating above their auto-ignition temperature.

6.3.4.3 Class 2

Services not included in other classes are in Class 2. This classification includes the majority of unit process piping and selected off-site piping. Typical examples of these services include but are not necessarily limited to those containing the following:

- a) on-site hydrocarbons that will slowly vaporize during release such as those operating below the boiling point but above the flash point,
- b) on-site hydrogen, fuel gas, and natural gas,
- c) on-site strong acids and caustics.

6.3.4.4 Class 3

Services that are either flammable but do not significantly vaporize when they leak, i.e. below the flash point, or flammable but are located in remote areas and operate below the boiling point are in Class 3. Services that are potentially harmful to human tissue but are located in remote areas may be included in this class. Examples of Class 3 service include, but are not necessarily limited to, those containing the following:

- a) on-site hydrocarbons that will not significantly vaporize during release such as those operating below the flash point;
- b) off-site distillate and product lines to and from storage and loading;
- c) tank farm piping;
- d) off-site acids and caustics;
- e) off-site hydrogen, fuel gas and natural gas; and
- f) Other lower risk hydrocarbon piping that does not fall in Class 1, 2, or 4.

6.3.4.5 Class 4

Services that are essentially nonflammable and nontoxic are in Class 4, as are most utility services. Inspection of Class 4 piping is optional and usually based on reliability needs and business impacts as opposed to safety or environmental impact. Examples of Class 4 service include, but are not necessarily limited to, those containing the following:

- a) steam and steam condensate;
- b) air;
- c) nitrogen;
- d) water, including boiler feed water or stripped sour water;
- e) lube oil, seal oil;
- f) ASME B31.3, Category D services;
- g) plumbing and sewers.

6.4 Extent of Visual External and CUI Inspections

External visual inspections, including inspections for CUI, should be conducted at intervals no greater than those listed in Table 1. Alternatively, external visual inspection intervals or due dates can be established by using a valid RBI assessment conducted in accordance with API 580. This external visual inspection for potential CUI is also to assess insulation condition and shall be conducted on all piping systems susceptible to CUI. The results of the visual inspection should be documented to facilitate follow-up inspections.

Following the external visual inspection of susceptible systems, additional examination is required for the inspection of CUI. The extent and type of the additional CUI inspection are listed in Table 2. Damaged insulation at higher elevations may result in CUI in lower areas remote from the damage. NDE inspection for CUI should also be conducted as listed in Table 2 at suspect locations operating between 10 °F (–12 °C) and 350 °F (175 °C) for carbon steel and low alloy steel piping. RT or insulation removal and visual inspection is normally required for this inspection at damaged or suspect locations. Other NDE assessment methods may be used where applicable. If the inspection of the damaged or suspect areas has located significant CUI, additional areas should be inspected and, where warranted, up to 100 % of the circuit should be inspected.

Table 2—Recommended Extent of CUI Inspection Following Visual Inspection for Susceptible Piping^a

Pipe Class	At Damaged Insulation Locations	At Non-damaged Locations
	Approximate Amount of Examination with NDE or Insulation Removal at Areas with Damaged Insulation	Approximate Amount of CUI Inspection with NDE or Insulation Removal at Areas without Damaged Insulation ^b
1	75 %	50 %
2	50 %	33 %
3	25 %	10 %
4	Optional	Optional

^a Susceptible piping is piping systems operating within the susceptible temperature ranges as indicated in API 574.

^b The 3rd column are additional areas to consider inspecting and is not progressive from the 2nd column

The extent of the CUI program described in Table 2 should be considered as target levels for piping systems and locations with no CUI inspection experience. It is recognized that several factors may affect the likelihood of CUI to include:

- a) local climatic conditions,
- b) insulation design and maintenance,
- c) coating quality,
- d) service conditions.

Facilities with CUI inspection experience may increase or reduce the CUI inspection targets of Table 2. An exact accounting of the CUI inspection targets is not required. The owner/user may confirm inspection targets with operational history or other documentation.

Piping systems that are known to have a remaining life of over 10 years or that are adequately protected against external corrosion need not be included for the NDE inspection recommended in Table 2. However, the condition of the insulating system or the outer jacketing, such as a cold-box shell, should be observed periodically by operating or

other personnel. If deterioration is noted, it should be reported to the inspector. The following are examples of these systems:

- a) piping systems insulated effectively to preclude the entrance of moisture,
- b) jacketed cryogenic piping systems,
- c) piping systems installed in a cold box in which the atmosphere is purged with an inert gas,
- d) piping systems in which the temperature being maintained is sufficiently low or sufficiently high to preclude the presence of water.

The external visual inspection on bare piping is to assess the condition of paint and coating systems, to check for external corrosion, and to check for other forms of deterioration.

6.5 Extent of Thickness Measurement Inspection and Data Analysis

6.5.1 CML Monitoring

To satisfy inspection interval requirements, each thickness measurement inspection should obtain thickness readings on a representative sampling of the total number of CMLs on each circuit (see 5.6). It is not the intent of this Code that every established CML needs to be measured each time. A statistical sampling of active CMLs may be monitored. In addition some CMLs may be documented as inactive and therefore do not need to be measured and would not be considered overdue. This representative sampling should include data for all the various types of components and orientations (horizontal and vertical) found in each circuit. This sampling also shall include CMLs with the earliest renewal date as of the previous inspection. Where general thinning is predicted, this sampling should include all the various types of components within the circuit. Where localized damage mechanisms are identified, sampling should also include the location and orientation (top/bottom, inside/outside radius, etc.) where the damage is most likely to occur. The number and specific CMLs to be monitored at each inspection shall be determined by the inspector in consultation with a piping engineer and/or corrosion specialist where non-uniform corrosion or other damage mechanisms are expected. Therefore, scheduled inspection of circuits should obtain as many measurements as necessary to satisfactorily monitor the type and extent of damage anticipated in each piping system. If RBI is used to set the inspection interval or due date, CMLs not required for inspection per the RBI assessment do not need to be inspected in accordance with the recommended maximum inspection intervals in Table 1.

To determine the extent of thickness measurements necessary in order to develop a corrosion rate and remaining life, two basic approaches are acceptable as discussed below.

6.5.2 Point-to-Point Method

An analysis method, whereby the corrosion rate, remaining life and re-inspection interval is determined for each individual CML. Future inspections are managed based on the worst case $1/2$ life established at each CML location. During a re-inspection of a piping system, all of the CMLs may be re-inspected or only those that are coming due. This method can lead to frequent inspections of the same piping system if not carefully managed. It is generally not possible to apply a statistical analysis with the point-to-point method since 1) a relationship of one CML to another has not been established, making it difficult to compare corrosion rates in the circuit or between CMLs, and 2) the individual CML rates may be generated over significantly different time periods, when operating conditions may have changed.

6.5.3 Circuit Analysis Method

Where piping has been properly circuitized into common corrosion mechanisms and expected rates, a statistical analysis may be used to determine a representative circuit corrosion rate and inspection interval. There are a number

of considerations for using a statistical analysis approach that are necessary to remain appropriately conservative, some of which include the following.

- a) Approach is generally applicable to damage mechanisms that produce uniform and some mildly localized corrosion environments.
- b) Locations that exhibit significantly different corrosion rates and locations with shorter remaining life may need to be analyzed separately.
- c) A sampling statistic should be considered to check the statistical confidence factor given the variability of the data set (within a circuit).
- d) The number of data points (CMLs) may need to be adjusted to achieve the desired statistical confidence before employing a statistical methodology.
- e) A safety factor or confidence interval, which may be dependent on the expected damage mechanisms and may additionally account for circuit complexity, should be considered to account for uncertainties such as measurement error and overall failure risk.
- f) CML re-inspection shall not be extended beyond the date projected to reach the established minimum required thickness. Absolute limits should be considered for re-inspection of CMLs based on the likelihood of failure (e.g., time or thickness limit).

As a minimum, the worst-case CMLs within the circuit shall be inspected at the next established inspection interval.

6.5.4 Data Analysis

Some level of data analysis is recommended under both approaches. Since the calculated corrosion rate used to predict the future remaining life was a product of the prior operating history, it is important to check for any acceleration of the corrosion rate over time and to be aware of planned operational changes. Good quality MOC and IOW programs are necessary where critical process variables that may affect corrosion/damage rate or susceptibility are tracked. Additional data analysis should consider the following.

- a) Is the measured rate within the expected / predicted range?
- b) Is the short rate significantly different from the long rate?
- c) Has the variability (or standard deviation) within the circuit data increased significantly over time?
- d) Do particular components, orientations, sections within the circuit or other identifiable features of the circuit exhibit significantly different rates?
- e) Have data anomalies been resolved, either through a review process or verification readings, prior to data analysis?

In general both approaches should be developed considering the potential active damage mechanisms within the piping system. Representative CMLs should be primarily based on the locations where the damage mechanisms are likely to be most active but should also include a sampling of all sizes, orientations, component types and design features (e.g. control valve stations, equipment inlets/outlets, alternate flow piping, etc) within the line or circuit. This sampling also shall include CMLs with the earliest renewal date as of the previous inspection.

For general corrosion, it may not be necessary to identify the specific orientation of the sample point. Where localized damage mechanisms are expected, sampling should include the orientation (top/bottom, inside/outside radius, etc.) to help identify the specific active mechanism and provide data for future adjustments to CML locations. The number

and specific CMLs to be monitored at each inspection shall be determined by the inspector in consultation with a piping engineer and/or corrosion specialist where non-uniform corrosion or other damage mechanisms are expected. Statistical tools may be used to determine or adjust the CML quantities when prior data are available. For new circuits or those with a change in service, data from a similar service may be applied to estimate CML quantities and/or locations. Circuit inspections should include as many measurements as necessary to satisfactorily monitor the type and extent of damage anticipated in each piping system. CMLs that are not driving the next inspection interval do not necessarily need to be inspected in accordance with the recommended maximum inspection intervals in Table 1. If a circuit statistical analysis method is to be performed, a representative sampling of all CMLs should be taken, to avoid skewing the data. Representative sampling is not an important consideration using the point to point method.

In addition, some CMLs may be documented as “inactive” or “archived”. These are CML points that have essentially been eliminated from the active registry but are being maintained for historical record purposes. There are several reasons to consider inactivating or archiving CMLs, including; inappropriate placement of CML, sufficient coverage by other CMLs, lack of historical corrosion activity, inaccessible during operation (e.g. furnace tubes), considered as “downtime/turnaround” only CMLs, etc. Although these CMLs may be maintained within the system (or electronic IDMS), they do not need to be measured on calculated intervals and would not be considered as overdue.

6.6 Extent of Inspections on Small-bore Piping, Deadlegs, Auxiliary Piping, and Threaded Connections

6.6.1 Small Bore Piping (SBP)

SBP that is primary process piping shall be inspected in accordance with all the requirements of this document. As with larger diameter piping, inspection practices for SBP shall take into consideration damage mechanisms in API 571 other than just wall thinning (e.g. stress corrosion cracking, hydrogen induced cracking, embrittlement, etc). Specific attention should be paid to damage that may have been inflicted by mechanical overloading on SBP since the strength and support systems for SBP are sometimes not adequate to avoid overload (e.g. vents, drains, bridles, etc).

Where RBI is not in use, SBP that is secondary process piping has different minimum requirements depending upon service classification. Class 1 and 2 secondary SBP shall be inspected to the same requirements as primary process piping. Inspection of Class 3 and Class 4 secondary SBP is optional at the owner-users discretion depending upon reliability and risk.

Insulated SBP should receive the same inspection practices for CUI as the primary piping or vessels to which it is attached. Insulation stripping and radiography are the preferred inspection methods for insulated SBP. Attention should be paid to insulation system resealing on SBP

Reference API 574 for multiple design, fabrication, installation and operating issues that can affect the likelihood of failure for SBP systems.

6.6.2 Deadleg Inspection

Deadlegs, including both large bore and small bore piping (e.g. level bridles), can be areas of increased corrosion requiring special attention if they are deemed potentially corrosive by a corrosion specialist because of: the accumulation of contaminated water, solid materials, different temperatures from the main line or the accumulation or concentration of corrosive species (e.g. ammonium salts, organic acids, hydrogen sulfide and acidic deposits). Risk assessment can be useful in determining which piping system deadlegs may be a higher threat to accelerated corrosion than active piping circuits. Deadlegs that are part of primary piping systems should be considered at greater risk because of the inability to valve them off in the event of a leak and the higher potential consequence of a large leak.

Consideration should be given to removing potentially corrosive deadlegs that are non-essential. Corrosion specialists should be consulted for placement of CMLs on deadlegs because of their potential for localized corrosion,

especially with regard to accelerated corrosion above and below liquid interfaces. Infrared thermography may be useful for locating liquid interfaces in deadlegs. Inspections of horizontal deadlegs that may not be liquid full should have examination points in all four quadrants of any CMLs.

Potentially corrosive deadlegs with CMLs should be tracked in a separate piping circuit from the mainline piping. These deadlegs or low points are typically identified and documented in the inspection records and on inspection ISO's. Deadlegs may be combined into one circuit if their anticipated damage mechanisms and corrosion rates are similar. Inspections should include profile radiography on small diameter deadlegs, such as vents and drains, and scanning UT or RT on larger diameter deadlegs. Other examination techniques for deadlegs include EMAT and PEC. Profile RT should be employed for deadlegs that may be susceptible to fouling deposits that could cause underdeposit corrosion or other integrity problems (e.g. fouling in relief lines).

Deadlegs that may collect water and be susceptible to freezing from external ambient conditions should be adequately insulated and heat traced for such cases.

6.6.3 Auxiliary Piping Inspection

Inspection of auxiliary SBP associated with instruments and machinery is optional and the need for which would typically be determined by risk assessment. Criteria to consider in determining whether auxiliary SBP will need some form of inspection include the following:

- a) piping classification;
- b) potential for environmental or fatigue cracking, particularly on non-braced SBP (e.g. reciprocating and centrifugal compressors, flow induced vibration);
- c) potential for corrosion based on experience with adjacent primary systems;
- d) potential for CUI;
- e) potential for fatigue, erosion and/or corrosion on thermowells.

6.6.4 Threaded-connection Inspection and Mitigation

Inspection of threaded connections should be according to the requirements listed above for small-bore and auxiliary piping. When selecting CMLs on threaded connections, include those threaded connections that can be radiographed during scheduled inspections.

When seal-welding threaded connections to reduce likelihood of threaded connection failure scenarios, pay close attention to weld prep cleanliness to avoid welding defects and cover all threads completely.

SBP connections associated with rotating equipment, especially threaded connections are often subject to fatigue damage. As such, they should be periodically assessed and considered for possible renewal with a thicker wall or upgrading joint design. The need for such renewal will depend on several issues, including the following:

- a) classification of piping,
- b) magnitude and frequency of vibration,
- c) amount of unsupported weight,
- d) current piping wall thickness,
- e) whether or not the system can be maintained on-stream,

- f) corrosion rate,
- g) intermittent service.

6.7 Inspection and Maintenance of Pressure-relieving Devices (PRDs)

6.7.1 General

PRDs shall be tested and repaired by a repair organization experienced in pressure relieving device maintenance. PRDs should be inspected, tested, and maintained in accordance with API 576.

6.7.2 Quality Assurance Process for PRDs

Each equipment repair organization shall have a fully documented quality assurance system. As a minimum, the following shall be included in the quality assurance manual:

- a) title page;
- b) revision log;
- c) contents page;
- d) statement of authority and responsibility;
- e) organizational chart;
- f) scope of work;
- g) drawings and specification controls;
- h) requirements for material and part control;
- i) repair and inspection program;
- j) requirements for welding, NDE, and heat treatment;
- k) requirements for valve testing, setting, leak testing, and sealing;
- l) general example of the valve repair nameplate;
- m) requirements for calibrating measurement and test gauges;
- n) requirements for updating and controlling copies of the quality control manual;
- o) sample forms;
- p) training and qualifications required for repair personnel;
- q) requirements for handling of non-conformances.

Each repair organization shall also have a fully documented training program that shall ensure that repair personnel are qualified within the scope of the repairs.

6.7.3 PRD Testing and Inspection Intervals

6.7.3.1 General

Pressure-relieving devices shall be tested and inspected at intervals that are frequent enough to verify that the valves perform reliably in the particular service conditions. Other pressure-relieving devices (e.g. rupture disks and vacuum-breaker valves) shall be inspected at intervals based on service conditions. The inspection interval for all pressure-relieving devices is determined by the inspector, engineer, or other qualified individual per the owner/user's quality assurance system.

6.7.3.2 PRD Testing and Inspection Intervals

Unless documented experience and/or an RBI assessment indicates that a longer interval is acceptable, test and inspection intervals for pressure-relieving devices in typical process services should not exceed:

- a) 5 years for typical process services, and
- b) 10 years for clean (non-fouling) and noncorrosive services.

When a pressure-relieving device is found to be heavily fouled or stuck, or when a PRD fails an as received pop test, the inspection and testing interval shall be reduced unless a review shows that the device will perform reliably at the current interval. The owner user should define the criteria which constitute an "As received" pop test failure. The owner user may define criteria for failure based on "As received" pop test pressure as a percentage of set pressure. As a default criteria for a valve being stuck shut, use a max 150 % of set pressure beyond which the valve is classified as stuck shut if it does not pop, and the test is discontinued. The review should determine the cause of the failure or the reasons for the pressure-relieving device not operating properly. When PRDs are removed for inspection and testing, inlet and outlet lines should be visually inspected for fouling and plugging.

Refer to API 576 for additional information on PRD pop test results and investigations.

7 Inspection Data Evaluation, Analysis, and Recording

7.1 Corrosion Rate Determination

7.1.1 General

The owner/user may use either the Point-to-Point analysis method or a statistical analysis method, or a combination of both, to determine the long term or short time corrosion rates.

7.1.2 Point-to-Point Method

The Long Term (LT) corrosion rate of an individual CML shall be calculated from the following formula:

$$\text{Corrosion rate (LT)} = \frac{t_{\text{initial}} - t_{\text{actual}}}{\text{time (years) between } t_{\text{initial}} \text{ and } t_{\text{actual}}} \quad (1)$$

The Short Term (ST) corrosion rate of an individual CML shall be calculated from the following formula:

$$\text{Corrosion rate (ST)} = \frac{t_{\text{previous}} - t_{\text{actual}}}{\text{time (years) between } t_{\text{previous}} \text{ and } t_{\text{actual}}}$$

where

- t_{initial} is the thickness, in inches (millimeters), at the same location as tactual measured at initial installation or at the commencement of a new corrosion rate environment;
- t_{previous} is the thickness, in inches (millimeters), at the same location as tactual measured during one or more previous inspections.

LT and ST corrosion rates should be compared to see which results in the shortest remaining life as part of the data assessment. The authorized inspector, in consultation with a corrosion specialist, shall select the corrosion rate that best reflects the current process (see 6.3.3 for inspection interval determination).

7.1.3 Statistical Analysis Method

The Owner–User may elect to use a statistical analysis method (e.g. probability plots or related tools) to establish a representative corrosion, remaining life estimate and/or re-inspection date. Any statistical approach shall be documented. Care shall be taken to ensure that the statistical treatment of data results reflects a reasonably conservative representation of the various pipe components within the circuit. Statistical analysis employing point measurements is not applicable to piping circuits with significant localized unpredictable corrosion mechanisms (See additional notes and statistical analysis in 6.5). There are many statistical tools that can be employed once Piping Circuits have been properly established. While such calculations offer a convenient means to numerically summarize Circuit data, it is often the combination of descriptive statistics plus data visualization through statistical plots that provide the most useful results.

See API 574 for additional discussion on statistical analysis methods.

7.2 Remaining Life Calculations

The remaining life shall be calculated from the following formula:

$$\text{Remaining life (years)} = \frac{t_{\text{actual}} - t_{\text{required}}}{\text{corrosion rate [inches (mm) per year]}} \quad (2)$$

where

- t_{actual} is the actual thickness, in inches (millimeters), measured at the time of inspection for a given location or component as specified in 5.7.
- t_{required} is the required thickness, in inches (millimeters), at the same location or component as the actual measurement computed by the design formulas (e.g. pressure and structural) before corrosion allowance and manufacturer's tolerance are added.

7.3 Newly Installed Piping Systems or Changes in Service

For new piping systems and piping systems for which service conditions are being changed, one of the following methods shall be employed to determine the probable rate of corrosion from which the remaining wall thickness at the time of the next inspection can be estimated.

- a) A corrosion rate for a piping circuit may be calculated from data collected by the owner/user on piping systems of similar material in comparable service and comparable operating conditions.
- b) If data for the same or similar service are not available, a corrosion rate for a piping circuit may be estimated from the owner/user's experience or from published data on piping systems in comparable service.

- c) If the probable corrosion rate cannot be determined by either method listed in 7.3a) or 7.3b), the initial thickness measurement determinations shall be made after no more than three months of service by using nondestructive thickness measurements of the piping system. Corrosion monitoring devices, such as corrosion coupons or corrosion probes, may be useful in establishing the timing of these thickness measurements. Subsequent measurements shall be made after appropriate intervals until the corrosion rate is established.

7.4 Existing and Replacement Piping

Corrosion rates shall be calculated on one of the methods identified in 7.1. For repaired or in-kind replacement piping, the corrosion rate shall be established based on the previous worse case measured rate at the replacement location or the circuit average rate.

If calculations indicate that an inaccurate rate of corrosion has been assumed, the rate to be used for the next period shall be adjusted to agree with the actual rate found.

7.5 MAWP Determination

The MAWP for the continued use of piping systems shall be established using the applicable code. Computations may be made for known materials if all the following essential details are known to comply with the principles of the applicable code:

- a) upper and/or lower temperature limits for specific materials,
- b) quality of materials and workmanship,
- c) inspection requirements,
- d) reinforcement of openings,
- e) any cyclical service requirements.

For unknown materials, computations may be made assuming the lowest grade material and joint efficiency in the applicable code. When the MAWP is recalculated, the wall thickness used in these computations shall be the actual thickness as determined by inspection minus twice the estimated corrosion loss before the date of the next inspection (see 6.3.3). Allowance shall be made for the other loadings in accordance with the applicable code. The applicable code allowances for pressure and temperature variations from the MAWP are permitted provided all of the associated code criteria are satisfied.

Annex D contains two examples of calculations of MAWP illustrating the use of the corrosion half-life concept.

7.6 Required Thickness Determination

The required thickness of a pipe shall be the greater of the pressure design thickness or the structural minimum thickness. For services with high risk, the piping engineer should consider increasing the required thickness to provide for unanticipated or unknown loadings, or undiscovered metal loss. See API 574, Second Edition, Section 11 for information on the determination of pressure design thicknesses, structural minimum thicknesses, minimum required thicknesses, and minimum alert thicknesses. Table 7 in Section 12 of API 574 provides examples of minimum alert thicknesses and default minimum structural thicknesses for carbon and low alloy steel piping operating below 400 °F (205 °C).

7.7 Assessment of Inspection Findings

Pressure containing components found to have degradation that could affect their load carrying capability [pressure loads and other applicable loads (e.g. weight, wind, etc., per API 579-1/ASME FFS-1)] shall be evaluated for continued service or removed from service until corrective actions/repairs are performed. Fitness-for-Service techniques, such as those documented in API 579-1/ASME FFS-1, latest edition, may be used for this evaluation. The Fitness-for-Service techniques used shall be applicable to the specific degradation observed. The following techniques may be used as applicable.

- a) To evaluate metal loss in excess of the corrosion allowance, a Fitness-For-Service assessment may be performed in accordance with one of the following parts of API 579-1/ASME FFS-1. This assessment requires the use of a future corrosion allowance, which shall be established, based on 7.1.
- b) Assessment of General Metal Loss—API 579-1/ASME FFS-1, Part 4.
- c) Assessment of Local Metal Loss—API 579-1/ASME FFS-1, Part 5.
- d) Assessment of Pitting Corrosion—API 579-1/ASME FFS-1, Part 6.
- e) To evaluate blisters and laminations, a Fitness-for-Service assessment should be performed in accordance with API 579-1/ASME FFS-1, Part 7. In some cases, this evaluation will require the use of a future corrosion allowance, which shall be established, based on 7.1.
- f) To evaluate weld misalignment and piping distortions, a Fitness-for-Service assessment should be performed in accordance with API 579-1/ASME FFS-1, Part 8.
- g) To evaluate crack-like flaws, a Fitness-for-Service assessment should be performed in accordance with API 579-1/ASME FFS-1, Part 9.
- h) To evaluate the effects of fire damage, a Fitness-for-Service assessment should be performed in accordance with API 579-1/ASME FFS-1, Part 11.

7.8 Piping Stress Analysis

Piping shall be supported and guided so that:

- a) its weight is carried safely,
- b) it has sufficient flexibility for thermal expansion or contraction, and
- c) it does not vibrate excessively, and
- d) accounts for other loads (e.g. those included in the original code of construction).

Piping flexibility is of increasing concern the larger the diameter of the piping and the greater the difference between ambient and operating temperature conditions.

Piping stress analysis to assess system flexibility and support adequacy is not normally performed as part of a piping inspection. However, many existing piping systems were analyzed as part of their original design or as part of a re-rating or modification, and the results of these analyses can be useful in developing inspection plans. When unexpected movement of a piping system is observed, such as during an external visual inspection (see 5.5.5), the inspector should discuss these observations with the piping engineer and evaluate the need for conducting a piping stress analysis.

See API 574 for more information on pressure design, minimum required and structural minimum thicknesses, including formulas, example problems and default tables of suggested minimums.

Piping stress analysis can identify the most highly stressed components in a piping system and predict the thermal movement of the system when it is placed in operation. This information can be used to concentrate inspection efforts at the locations most prone to fatigue damage from thermal expansion (heat up and cool down) cycles and/or creep damage in high-temperature piping. Comparing predicted thermal movements with observed movement can help identify the occurrence of unexpected operating conditions and deterioration of guides and supports. Consultation with the piping engineer may be necessary to explain observed deviations from the analysis predictions, particularly for complicated systems involving multiple supports and guides between end points.

Piping stress analysis also can be employed to help solve observed piping vibration problems. The natural frequencies in which a piping system will vibrate can be predicted by analysis. The effects of additional guiding can be evaluated to assess its ability to control vibration by increasing the system's natural frequencies beyond the frequency of exciting forces, such as machine rotational speed. It is important to determine that guides added to control vibration do not adversely restrict thermal expansion.

7.9 Reporting and Records for Piping System Inspection

7.9.1 Permanent and Progressive Records

Piping system owner/users shall maintain permanent and progressive records of their piping systems and pressure-relieving devices. Permanent records will be maintained throughout the service life of each piping system. As a part of these records, progressive inspection and maintenance records will be regularly updated to include new information pertinent to the operation, inspection, and maintenance history of the piping system. See also API 574 for more information of piping system records.

7.9.2 Types of Piping Records

Piping system and pressure-relieving device records shall contain four types of information pertinent to mechanical integrity as follows.

- a) Fabrication, Construction and Design Information to the Extent Available—For example, MDRs, MTRs, weld maps, WPS/PQR, design specification data, piping design calculations, NDE records, heat treat records, pressure-relieving device sizing calculations and construction drawings.
- b) Inspection History—For example, inspection reports, and data for each type of inspection conducted (e.g. internal, external, thickness measurements), and inspection recommendations for repair. Inspection reports shall document the date of each inspection and/or examination, the date of the next scheduled inspection, the name (or initials) of the person who performed the inspection and/or examination, the serial number or other identifier of the equipment inspected, a description of the inspection and/or examination performed, and the results of the inspection and/or examination. Piping RBI records should be in accordance with API 580.
- c) Repair, Alteration, and Re-rating Information—For example:
 - 1) repair and alteration forms if prepared;
 - 2) reports indicating that piping systems still in-service with either identified deficiencies, temporary repairs or recommendations for repair, are suitable for continued service until repairs can be completed; and
 - 3) re-rating documentation (including re-rating calculations and new design conditions).

- d) Fitness-for-Service assessment documentation requirements are described in API 579-1/ASME FFS-1, specific documentation requirements for the type of flaw being assessed are provided in the appropriate part of API 579-1/ASME FFS-1.

7.9.3 Operating and Maintenance Records

Site operating and maintenance records, such as operating conditions, including process upsets that may affect mechanical integrity, changes in service, mechanical damage from maintenance should also be available to the inspector.

7.9.4 Computer Records

The use of a computer-based system for storing, calculating, and analyzing data should be considered in view of the volume of data that will be generated as part of a piping inspection program. Computer programs are particularly useful for the following:

- a) storing and analyzing the actual thickness readings;
- b) calculating short and long-term corrosion rates, retirement dates, MAWP, and re-inspection intervals;
- c) highlighting areas of high corrosion rates, piping circuits overdue for inspection, piping close to the minimum required thickness, and other information.

7.9.5 Piping Circuit Records

The following information should be recorded for each piping circuit on which CMLs are located:

- a) material of construction/piping specification;
- b) piping diameter;
- c) operating and design pressures and temperatures;
- d) ANSI flange rating;
- e) process fluids;
- f) piping classification (if RBI is not being used);
- g) insulation, heat tracing, PWHT;
- h) whether the circuit is a deadleg, injection point, intermittent service, or other special circuit;
- i) the corrosion rate and remaining service life of, at least, the limiting examination point on the circuit;
- j) maximum interval for external inspection;
- k) maximum interval for thickness measurement inspection;
- l) any unusual or localized corrosion mode that would require specialized inspection techniques;
- m) particular circuit features that might subject it to rapid corrosion increases in the event of a process upset or loss of injection fluid flow.

7.9.6 Inspection Isometric Drawings (ISOs)

The primary purpose of inspection ISOs is to identify the location of CMLs and to identify the location of any recommended maintenance. Inspection ISOs are recommended and should contain the following:

- a) all significant components of the piping circuits (e.g. all valves, elbows, tees, branches, etc.);
- b) material of construction and specification breaks;
- c) diameter of piping;
- d) insulated or not;
- e) all secondary piping for Class 1 (or high consequence RBI) piping circuits;
- f) secondary piping up to the block valve that is normally used for Class 2 (or appropriate RBI consequence) unit pipe;
- g) all CMLs with appropriate information to locate the CMLs;
- h) adequate orientation and scale to provide legible detail;
- i) piping-circuit numbers and changes;
- j) continuation drawing numbers;
- k) location and type of pipe supports.

Inspection ISOs are recommended for all unit piping and all Class 1 (or high consequence RBI) pipe rack piping on which CMLs have been identified for thickness measurement. Alternate methods for pipe rack piping which adequately describes the system without ISOs may be used.

Inspection ISOs are recommended for Class 2 (or appropriate RBI consequence) rack piping with CMLs, except that grid type drawings may be used if all other details are shown. The use of local details or local isometrics is acceptable to show the location of CMLs on grid drawings.

Inspection ISOs do not need to be drawn to scale or show dimensions unless necessary to locate CMLs.

7.10 Inspection Recommendations for Repair or Replacement

A list of repair or replacement recommendations (includes recommendations for non-conformances) that impact piping integrity is required and shall be kept current. The recommendation tracking system shall include:

- a) recommended corrective action or repair and date,
- b) priority or target date for recommended action,
- c) piping system identifier (e.g. piping system or circuit number) that the recommendation affects.
- d) list of temporary repairs that may need follow-up monitoring and eventual replacement.

A management system is required for tracking and reviewing outstanding recommendations on a periodic basis.

7.11 Inspection Records for External Inspections

Results of external piping system inspections shall be documented. A combination of checklist and narrative record keeping is recommended when documenting inspection results. Checklists should serve the purpose of reminding record keepers of all the issues important to be included in piping inspection records; but narratives serve the purpose better than checklists for thoroughly documenting inspections results. The location of CUI inspections, either by insulation removal or NDE, should be identified. The location may be identified by establishing a CML on the appropriate inspection ISO or with marked-up construction ISOs and narrative reports.

7.12 Piping Failure and Leak Reports

Leaks and failures in piping that occur as a result of corrosion, cracking or mechanical damage shall be recorded and reported to the owner/user. As with other piping failures, leaks and failures in piping systems shall be investigated to identify and correct the cause of failure. See API 585 for more information on how to investigate piping failures. Temporary repairs to piping systems shall be documented in the inspection records.

7.13 Deferral of Inspections, Tests, and Examinations

Inspections, tests, or examinations for piping and associated pressure-relieving devices that cannot be completed by their due date may be deferred for a specified period, subject to the requirements in the following sub-sections.

Piping or pressure-relieving devices that are operated beyond the due date without a valid deferral in accordance with these requirements are not permitted by this code. Deferrals should be the occasional exception, not a frequent occurrence. All deferrals shall be documented. Piping or pressure-relieving devices that were granted a deferral can be operated to the new due date without being considered overdue for the deferred inspections, tests, or examinations.

7.13.1 Simplified Deferral

A simplified short-term deferral may be approved by the owner-user if all of the following conditions are met:

- a) The current due date for the inspection, test, or examination has not been previously deferred.
- b) The proposed new due date would not increase the current inspection/servicing interval or due date by more than 10 % or six months, whichever is less.
- c) A review of the current operating conditions, as well as the piping or pressure-relieving device history, has been completed with results that support a short-term/one-time deferral.
- d) The deferral request has the consent of the inspector representing or employed by the owner-user and an appropriate operations management representative(s).
- e) Updates to the piping or pressure-relieving device records with deferral documentation are complete before it is operated beyond the original due date.

7.13.2 Deferral

Deferral requests not meeting the conditions of a simplified deferral shall follow a documented deferral procedure/process that includes all of the following minimum requirements:

- a) Perform a documented risk-assessment or update an existing RBI assessment to determine if the proposed deferral date would increase risk above acceptable risk threshold levels as defined by the owner-user. The risk assessment may include any of the following elements as deemed necessary by the owner/user:
 - fitness for service analysis results;
 - consequence of failure;
 - applicable damage mechanism susceptibilities and rates of degradation;
 - calculated remaining life;
 - historical conditions/findings from inspections, tests, and examinations and their technical significance;
 - extent and/or probability of detection (i.e. effectiveness) of previous inspections, tests, or examinations, as well as the amount of time that has elapsed since they were last performed;
 - considerations for any previous changes to inspection or test intervals (e.g. reductions in interval due to deteriorating conditions);
 - disposition(s) of any previous requests for deferral on the same piping or pressure-relieving device;
 - historical conditions/findings for piping or pressure-relieving devices in similar service, if available.
- b) Determine if the deferral requires the implementation of, or modification to existing integrity operating windows or operating process control limits.
- c) Review the current inspection plan to determine if modifications are needed to support the deferral.
- d) Obtain the consent and approval of appropriate piping personnel including the inspector representing, or employed by the owner-user and appropriate operations management representative(s).
- e) Updates to the piping or pressure-relieving device records with deferral documentation are complete before it is operated beyond the original due date.

8 Repairs, Alterations, and Rerating of Piping Systems

8.1 Repairs and Alterations

8.1.1 General

The principles of ASME B31.3 or the code to which the piping system was built shall be followed to the extent practical for in-service repairs. ASME B31.3 is written for design and construction of piping systems. However, most of the technical requirements on design, welding, examination, and materials also can be applied in the inspection, rerating, repair, and alteration of operating piping systems. When ASME B31.3 cannot be followed because of its new construction coverage (such as revised or new material specifications, inspection requirements, certain heat treatments, and pressure tests), the piping engineer or inspector shall be guided by API 570 in lieu of strict conformity to ASME B31.3. As an example of intent, the phrase "principles of ASME B31.3" has been employed in API 570, rather than "in accordance with ASME B31.3."

The principles and practices of API 577 shall also be followed for all welded repairs and modifications.

8.1.2 Authorization

All repair and alteration work shall be done by a repair organization as defined in Section 3 and shall be authorized by the inspector prior to its commencement. Authorization for alteration work to a piping system may not be given without prior consultation with, and approval by, the piping engineer. The inspector will designate any inspection hold points required during the repair or alteration sequence. The inspector may give prior general authorization for limited or routine repairs and procedures, provided the inspector is satisfied with the competency of the repair organization.

8.1.3 Approval

All proposed methods of design, execution, materials, welding procedures, examination, and testing shall be approved by the inspector or by the piping engineer, as appropriate. Owner/user approval of on-stream welding is required.

Welding repairs of cracks that occurred in-service should not be attempted without prior consultation with the piping engineer in order to identify and correct the cause of the cracking. Examples are cracks suspected of being caused by vibration, thermal cycling, thermal expansion problems, and environmental cracking.

The inspector shall approve all repair and alteration work at designated hold points and after the repairs and alterations have been satisfactorily completed in accordance with the requirements of API 570.

8.1.4 Welding Repairs (Including On-stream)

8.1.4.1 Temporary Repairs

For temporary repairs, including on-stream, a full encirclement welded split sleeve or box-type enclosure designed by the piping engineer may be applied over the damaged or corroded area. See various articles in ASME PCC-2 for more information on repairs to piping systems. Longitudinal cracks shall not be repaired in this manner unless the piping engineer has determined that cracks would not be expected to propagate from under the sleeve. In some cases, the piping engineer will need to consult with a fracture analyst. The design of temporary enclosures and repairs shall be approved by the piping engineer.

If the repair area is localized (for example, pitting or pinholes) and the SMYS of the pipe is not more than 40,000 psi (275,800 kPa), and a Fitness-for-Service analysis shows it is acceptable, a temporary repair may be made by fillet welding a properly designed split coupling or plate patch over the pitted or locally thinned area (see 8.1.4 for design considerations and Annex C for an example). The material for the repair shall match the base metal unless approved by the piping engineer. A fillet-welded patch shall not be installed on top of an existing fillet-welded patch. When installing a fillet-welded patch adjacent to an existing fillet-welded patch, the minimum distance between the toe of the fillet weld shall not be less than:

$$d = 4\sqrt{Rt} \quad (3)$$

where

d is the minimum distance between the toes of fillet welds of adjacent fillet weld attachments, in inches (millimeters);

R is the inside radius in inches (millimeters);

t is the minimum required thickness of the fillet-welded patch in inches (millimeters).

For minor leaks and thinning below T_{\min} , properly designed enclosures may be welded over the leak or thin piping while the piping system is in-service, provided the inspector is satisfied that adequate thickness remains in the actual location of the proposed weld and HAZ, and the piping component can withstand welding without the likelihood of further material damage, such as from caustic service. Any leak in a Class 1 service or where a risk ranking is determined to be high, shall be first reviewed by a piping engineer to determine if the work can be safely performed while the system remains on stream.

Temporary repairs should be removed and replaced with a suitable permanent repair at the next available maintenance opportunity. Temporary repairs may remain in place for a longer period of time only if approved and documented by the piping engineer.

8.1.4.2 Permanent Repairs

Repairs to defects found in piping components may be made by preparing a welding groove that completely removes the defect and then filling the groove with weld metal deposited in accordance with 8.2.

Corroded areas may be restored with weld metal deposited in accordance with 8.2. Surface irregularities and contamination shall be removed before welding. Appropriate NDE methods shall be applied after completion of the weld.

If it is feasible to take the piping system out of service, the defective area may be removed by cutting out a cylindrical section and replacing it with a piping component that meets the applicable code.

Insert patches (flush patches) may be used to repair damaged or corroded areas if the following requirements are met:

- a) full-penetration groove welds are provided;
- b) for Class 1 and Class 2 piping systems, the welds shall be 100 % radiographed or ultrasonically tested using NDE procedures that are approved by the inspector;
- c) patches may be any shape but shall have rounded corners [1 in. (25 mm) minimum radius].

See ASME PCC-2 Part 2 for more information on various welded repairs to piping systems.

8.1.5 Nonwelding Repairs (On-stream)

Temporary repairs of locally thinned sections or circumferential linear defects may be made on-stream by installing a properly designed and applied enclosure (e.g. bolted clamp, nonmetallic composite wrap, metallic and epoxy wraps, or other non-welded applied temporary repair). The design shall include control of axial thrust loads if the piping component being enclosed is (or may become) insufficient to control pressure thrust. The effect of enclosing (crushing) forces on the component also shall be considered. See ASME PCC-2 Part 4 for more information on nonmetallic composite wrap repair methods.

During turnarounds or other appropriate opportunities, temporary leak sealing and leak dissipating devices, (e.g., wire wrapping, mechanical clamps, etc) including temporary repairs on valves, shall be removed and appropriate actions taken to restore the original integrity of the piping system. The inspector and/or piping engineer shall be involved in determining repair methods and procedures. Temporary leak sealing and leak dissipating devices may remain in place for a longer period of time only if approved and documented by the piping engineer. From a mechanical integrity perspective, injection fittings on valves to seal fugitive (LDAR) emissions from valve stem seal are not considered to be temporary repairs. Their removal or valve replacement is at the discretion of the owner operator.

Procedures that include leak sealing fluids ("pumping") for process piping should be reviewed for acceptance by the inspector or piping engineer. The review should take into consideration the compatibility of the sealant with the

leaking material; the pumping pressure on the clamp (especially when re-pumping) and any resulting crushing forces; and; the risk of sealant affecting downstream flow meters, pressure relieving devices, or machinery; the risk of subsequent leakage at bolt threads causing corrosion or stress corrosion cracking of bolts; and the number of times the seal area is repumped.

See ASME PCC-2 Part 3 for more information on non-welded repairs for piping systems.

8.2 Welding and Hot Tapping

8.2.1 General

All repair and alteration welding shall be done in accordance with the principles of ASME B31.3 or the code to which the piping system was built.

Any welding conducted on piping components in operation shall be done in accordance with API 2201. The inspector shall use as a minimum the "Suggested Hot Tap Checklist" contained in API 2201 for hot tapping performed on piping components. See API 577 for further guidance on hot tapping and welding in-service.

8.2.2 Procedures, Qualifications, and Records

The repair organization shall use welders and welding procedures qualified in accordance with ASME B31.3 or the code to which the piping was built. See API 577 for guidance on welding procedures and qualifications.

The repair organization shall maintain records of welding procedures and welder performance qualifications. These records shall be available to the inspector prior to the start of welding.

8.2.3 Preheating and PWHT

8.2.3.1 General

Refer to API 577 for guidance on preheating and PWHT.

8.2.3.2 Preheating

Preheat temperatures used in making welding repairs shall be in accordance with the applicable code and qualified welding procedure. Exceptions for temporary repairs shall be approved by the piping engineer.

NOTE Preheating alone may not be considered as an alternative to environmental cracking prevention.

Piping systems constructed of steels initially requiring PWHT normally are postweld heat treated if alterations or repairs involving pressure retaining welding are performed.

8.2.3.3 PWHT

PWHT of piping system repairs or alterations should be made using the applicable requirements of ASME B31.3 or the code to which the piping was built. See 8.2.4 for an alternative preheat procedure for some PWHT requirements. Exceptions for temporary repairs shall be approved by the piping engineer and be in accordance with ASME PCC-2, Article 2.9.

Local PWHT may be substituted for 360° banding on local repairs on all materials, provided the following precautions and requirements are applied.

a) The application is reviewed, and a procedure is developed by the piping engineer.

- b) In evaluating the suitability of a procedure, consideration shall be given to applicable factors, such as base metal thickness, thermal gradients, material properties, changes resulting from PWHT, the need for full-penetration welds, and surface and volumetric examinations after PWHT. Additionally, the overall and local strains and distortions resulting from the heating of a local restrained area of the piping wall shall be considered in developing and evaluating PWHT procedures.
- c) A preheat of 300 °F (150 °C), or higher as specified by specific welding procedures, is maintained while welding.
- d) The required PWHT temperature shall be maintained for a distance of not less than two times the base metal thickness measured from the weld. The PWHT temperature shall be monitored by a suitable number of thermocouples (a minimum of two) based on the size and shape of the area being heat treated.
- e) Controlled heat also shall be applied to any branch connection or other attachment within the PWHT area.
- f) The PWHT is performed for code compliance and not for environmental cracking resistance.

8.2.4 Preheat or Controlled Deposition Welding Methods as Alternatives to Postweld Heat Treatment

8.2.4.1 General

In some instances, full PWHT may have potential adverse effects on equipment and piping. Nevertheless, the piping may have been originally PWHT'd or may require PWHT according to the original construction code. In these cases, preheat and controlled deposition welding may be used in lieu of PWHT, as described in 8.2.4.2 and 8.2.4.3. However, prior to using alternative methods, a piping engineer shall assure the alternative is suitable based on a metallurgical review. The review shall consider factors such as the reason for the original PWHT, susceptibility to stress corrosion cracking, stresses in the location of the weld, susceptibility to high temperature hydrogen attack, susceptibility to creep, etc.

The welding method shall be selected based on the rules according to the applicable code/standard. As well, the adequacy of the as-welded joint at operating and pressure test conditions should be considered.

When reference is made in this section to materials by the ASME designations, P-Numbers and Group Numbers, the requirements of this section apply to the applicable materials of the original code of construction, either ASME or other, which conform by chemical composition and mechanical properties to the ASME P-number and group number designations.

Pressure boundary process piping alterations or repair welds that initially required PWHT shall be postweld heat treated, with the exceptions listed in 8.2.4.2 and 8.2.4.3. If valid for the current rated design, the original joint efficiency factor may be used when alternative post weld heat treatments are practiced.

8.2.4.2 Preheating Method (Notch Toughness Testing Not Required)

The preheating method, when performed in lieu of PWHT, is limited to the following materials and weld processes:

- a) The materials shall be limited to P-No. 1, Group 1, 2, and 3, and to P-No. 3, Group 1 and 2 (excluding Mn-Mo steels in Group 2)
- b) The welding shall be limited to the shielded-metal-arc welding (SMAW), gas-metal-arc welding (GMAW), gas-tungsten-arc (GTAW), and flux-cored arc welding (FCAW) processes.

The welders and welding procedures shall be qualified in accordance with the applicable rules of the original code of construction, except that the PWHT of the test coupon used to qualify the procedure shall be omitted.

The weld area shall be preheated and maintained at a minimum temperature of 300°F (150°C) during welding. The 300 °F (150 °C) temperature should be checked to assure that 4 in. (100 mm) of the material or four times the material thickness (whichever is greater) on each side of the groove is maintained at the minimum temperature during welding. The maximum interpass temperature shall not exceed 600 °F (315 °C). When the weld does not penetrate through the full thickness of the material, the minimum preheat and maximum interpass temperatures need only be maintained at a distance of 4 in. (100 mm) or four times the depth of the repair weld, whichever is greater on each side of the joint.

The use of the preheat alternative requires consultation with the piping engineer who should consider the potential for environmental cracking and whether the welding procedure will provide adequate toughness. Examples of situations where this alternative could be considered include seal welds, weld metal buildup of thin areas, and welding support clips.

NOTE Notch toughness testing is not required when using this preheat method in lieu of PWHT.

8.2.4.3 Controlled-deposition Welding Method (Notch Toughness Testing Required)

The controlled-deposition welding method may be used in lieu of PWHT in accordance with the following:

- a) Notch toughness testing, such as that established by ASME B31.1, Chapter III Section 323, is necessary when impact tests are required by the original code of construction or the construction code applicable to the work planned.
- b) The materials shall be limited to P-No. 1, P-No. 3, and P-No. 4 steels.
- c) The welding shall be limited to the shielded-metal-arc welding (SMAW), gas-metal-arc welding (GMAW), flux-cored arc welding (FCAW), and gas-tungsten arc welding (GTAW) processes.
- d) A weld procedure specification shall be developed and qualified for each application. The welding procedure shall define the preheat temperature and interpass temperature and include the post-heating temperature requirement in f(8). The qualification thickness for the test plates and repair grooves shall be in accordance with Table 3. The test material for the welding procedure qualification shall be of the same material specification (including specification type, grade, class and condition of heat treatment) as the original material specification for the repair. If the original material specification is obsolete, the test material used should conform as much as possible to the material used for construction, but in no case shall the material be lower in strength or have a carbon content of more than 0.35 %.
- e) When impact tests are required by the construction code applicable to the work planned, the PQR shall include sufficient tests to determine if the toughness of the weld metal and the heat-affected zone of the base metal in the as-welded condition is adequate at the minimum design metal temperature (such as the criteria used in ASME B31.3). If special hardness limits are necessary (for example, as set forth in NACE RP 0472 and MR 0103) for corrosion resistance, the PQR shall include hardness tests as well.
- f) The WPS shall include the following additional requirements.
 - 1) The supplementary essential variables of ASME Code, Section IX, Paragraph QW-250, shall apply.
 - 2) The maximum weld heat input for each layer shall not exceed that used in the procedure qualification test.
 - 3) The minimum preheat temperature for welding shall not be less than that used in the procedure qualification test.
 - 4) The maximum interpass temperature for welding shall not be greater than that used in the procedure qualification test.

- 5) The preheat temperature shall be checked to assure that 4 in. (100 mm) of the material or four times the material thickness (whichever is greater) on each side of the weld joint will be maintained at the minimum temperature during welding. When the weld does not penetrate through the full thickness of the material, the minimum preheat temperature need only be maintained at a distance of 4 in. (100 mm) or four times the depth of the repair weld, whichever is greater on each side of the joint.
- 6) For the allowed welding processes in Item c, use only electrodes and filler metals that are classified by the filler metal specification with an optional supplemental diffusible-hydrogen designator of H8 or lower. When shielding gases are used with a process, the gas shall exhibit a dew point that is not higher than -60°F (-50°C). Surfaces on which welding will be done shall be maintained in a dry condition during welding and free of rust, mill scale and hydrogen producing contaminants such as oil, grease and other organic materials.
- 7) The welding technique shall be a controlled-deposition, temper-bead or half-bead technique. The specific technique shall be used in the procedure qualification test.
- 8) For welds made by SMAW, once filling is completed do not allow the weldment to cool below the minimum preheat temperature. As well, raise the weldment temperature to $500^{\circ}\text{F} \pm 50^{\circ}\text{F}$ ($260^{\circ}\text{C} \pm 30^{\circ}\text{C}$) for a minimum period of two hours. This assists out-gassing diffusion of any weld metal hydrogen picked up during welding. This hydrogen bake-out may be omitted when H4 filler metal (such as E7018-H4) is specified.
- 9) After the finished repair weld has cooled to ambient temperature, the final temper bead reinforcement layer shall be removed substantially flush with the surface of the base material.

Refer to WRC Bulletin 412 for additional supporting technical information regarding controlled deposition welding.

Table 3—Welding Methods as Alternatives to Post-weld Heat Treatment Qualification Thickness for Test Plates and Repair Grooves

Depth t of Test Groove Welded	Repair Groove Depth Qualified	Thickness T of Test Coupon Welded	Thickness Base Metal Qualified
t	$< t$	< 2 in (50 mm)	$< T$
t	$< t$	≥ 2 in (50 mm)	2 in (50 mm) to unlimited

^a The depth of the groove used for procedure qualification must be deep enough to allow removal of the required test specimen

8.2.5 Design

Butt joints shall be full-penetration groove welds.

Piping components shall be replaced when repair is likely to be inadequate. New connections and replacements shall be designed and fabricated according to the principles of the applicable code. The design of temporary enclosures and repairs shall be approved by the piping engineer.

New connections may be installed on piping systems provided the design, location, and method of attachment conform to the principles of the applicable code.

Fillet-welded patches require special design considerations, especially relating to weld-joint efficiency and crevice corrosion. Fillet-welded patches shall be designed by the piping engineer. A patch may be applied to the external surfaces of piping, provided it is in accordance with 8.1.3 and meets either of the following requirements:

- a) the proposed patch provides design strength equivalent to a reinforced opening designed according to the applicable code;

- b) the proposed patch is designed to absorb the membrane strain of the part in a manner that is in accordance with the principles of the applicable code, if the following criteria are met:
- 1) the allowable membrane stress is not exceeded in the piping part or the patch,
 - 2) the strain in the patch does not result in fillet weld stresses exceeding allowable stresses for such welds,
 - 3) an overlay patch shall have rounded corners (see Annex C).

Different components in the same piping system or circuit may have different design temperatures. In establishing the design temperature, consideration shall be given to process fluid temperatures, ambient temperatures, heating and cooling media temperatures, and insulation.

8.2.6 Materials

The materials used in making repairs or alterations shall be of known weldable quality, shall conform to the applicable code, and shall be compatible with the original material. For material verification requirements, see 5.12.

8.2.7 NDE

Acceptance of a welded repair or alteration shall include NDE in accordance with the applicable code and the owner/user's specification, unless otherwise specified in API 570. The principles and practices of API 577 shall also be followed. When surface and volumetric examinations are required, they shall be in accordance with ASME *BPVC* Section V (or equivalent).

8.2.8 Pressure Testing

After welding is completed, a pressure test in accordance with 5.11 shall be performed if practical and deemed necessary by the inspector. Pressure tests are normally required after alterations and major repairs. See ASME PCC-2, Article 5.1 for more information on conducting pressure tests. When a pressure test is not necessary or practical, NDE shall be utilized in lieu of a pressure test. Substituting appropriate NDE procedures for a pressure test after an alteration, re-rating, or repair may be done only after consultation with the inspector and the piping engineer. For existing insulated lines that are being pressure tested after repairs, re-rating, or alterations, it is not necessary to strip insulation on all existing welds. Pressure tests with longer hold times and observations of pressure gauges can be substituted for insulation stripping when the risks associated with leak under the insulation are acceptable.

When it is not practical to perform a pressure test of a final closure weld that joins a new or replacement section of piping to an existing system, all of the following requirements shall be satisfied.

- a) The new or replacement piping section is pressure tested and examined in accordance with the applicable code governing the design of the piping system, or if not practical, welds are examined with appropriate NDE, as specified by the authorized piping inspector.
- b) The closure weld is a weld between any pipe or standard piping component of equal diameter and thickness, axially aligned (not miter cut), and of equivalent materials. Where slip-on flanges or socket weld fittings are permitted by the specification for the piping system, they may be used within the limitations of that specification. Acceptable alternatives are:
 - 1) slip-on flanges for design cases up to Class 150 and 500 °F (260 °C); and
 - 2) socket-welded fittings for sizes NPS 2 or less and design cases up to 500 °F (260 °C). A spacer designed for socket welding or some other means shall be used to establish a minimum $1/16$ in. (1.6 mm) gap. Socket welds shall be per ASME B31.3 and shall be a minimum of two passes.

- c) Any final closure butt weld shall be of 100 % RT; or angle beam ultrasonic flaw detection may be used, provided the appropriate acceptance criteria have been established.
- d) MT or PT shall be performed on the root pass and the completed weld for butt welds and on the completed weld for fillet welds.

The owner/user shall specify industry-qualified UT angle beam examiners for closure welds that have not been pressure tested and for weld repairs identified by the piping engineer or authorized piping inspector.

8.3 Re-rating

Re-rating piping systems by changing the temperature rating or the MAWP may be done only after all of the following requirements have been met.

- a) Calculations are performed by the piping engineer or the inspector.
- b) All re-ratings shall be established in accordance with the requirements of the code to which the piping system was built or by computation using the appropriate methods in the latest edition of the applicable code or other industry standards approved by a SDO (e.g. API 579-1/ASME FFS-1).
- c) Current inspection records verify that the piping system is satisfactory for the proposed service conditions and that the appropriate corrosion allowance is provided.
- d) Re-rated piping systems shall be leak tested in accordance with the code to which the piping system was built or the latest edition of the applicable code for the new service conditions, unless one of the following is true.
 - 1) Documented records indicate a previous leak test was performed at greater than or equal to the test pressure for the new condition.
 - 2) The re-rate is an increase in the rating temperature that does not affect allowable tensile stress.
 - 3) The piping integrity is confirmed by appropriate nondestructive inspection techniques in lieu of testing after consultation with the inspector and piping engineer.
- e) The piping system is checked to affirm that the required pressure relieving devices are present, are set at the appropriate pressure, and have the appropriate capacity at set pressure.
- f) The piping system re-rating is acceptable to the inspector or piping engineer.
- g) All piping components in the system (such as valves, flanges, bolts, gaskets, packing, and expansion joints) are adequate for the new combination of pressure and temperature.
- h) Piping flexibility is adequate for design temperature changes.
- i) Appropriate engineering records are updated.
- j) A decrease in minimum operating temperature is justified by impact test results, if required by the applicable code.

9 Inspection of Buried Piping

9.1 General

Inspection of buried process piping (not regulated by the U.S. Department of Transportation) is different from other process piping inspection because significant external deterioration can be caused by corrosive soil conditions and

the inspection can be hindered by the inaccessibility of the affected areas of the piping. Important, non-mandatory references for underground piping inspection are API 574 and the following NACE documents: SP0102, SP0169, SP0274, and RP0502; and API 651.

Buried piping shall be inspected to determine its external surface condition. The inspection plans shall be based on an assessment of the effectiveness of the CP system (if any exists), whether the pipe was coated and on inspection information obtained from one or more of the following methods:

- a) during maintenance activity on connecting piping of similar material;
- b) from representative portions of the actual piping;
- c) from buried piping in similar circumstances;
- d) from permanently installed thickness monitoring devices;
- e) from inspections conducted with remote visual equipment, if possible; or
- f) from the results of cathodic protection surveys, or from guided wave examination used to locate areas of interest for follow-up inspection using more quantitative thickness measurement techniques.

9.2 Above-grade Visual Surveillance

Indications of leaks in buried piping may include a change in the surface contour of the ground, discoloration of the soil, softening of paving asphalt, pool formation, bubbling water puddles, or noticeable odor. Surveying the route of buried piping is one method of identifying problem areas.

9.3 Close-interval Potential Survey

The close-interval potential survey performed at ground level over the buried pipe can be used to locate areas where the cathodic protection systems may not be effective and active corrosion on the pipe's surface is present or may occur. However, it may not be a reliable method for corrosion wall loss inspection, since it can only infer wall loss from CP potential but not directly detect presence of wall loss.

Corrosion cells can form on both bare and coated pipe where the bare steel contacts the soil. Since the potential at the area of corrosion will be measurably different from an adjacent area on the pipe, the location of possible corrosion activity can be determined by this survey technique.

9.4 Pipe Coating Holiday Survey

The pipe coating holiday survey [e.g. direct current voltage gradient (DCVG)] can be used to locate coating defects on buried coated pipes, and it can be used on newly constructed pipe systems to ensure that the coating is intact and holiday-free. More often it is used to evaluate coating serviceability for buried piping that has been in-service for an extended period of time.

From survey data, the coating effectiveness and rate of coating deterioration can be determined. This information is used both for predicting corrosion activity in a specific area and for forecasting replacement of the coating for corrosion control.

9.5 Soil Resistivity

Corrosion of bare or poorly coated piping is often caused by a mixture of different soils in contact with the pipe surface. The corrosiveness of the soils can be determined by a measurement of the soil resistivity. Lower levels of

resistivity are relatively more corrosive than higher levels, especially in areas where the pipe is exposed to significant changes in soil resistivity.

Measurements of soil resistivity should be performed using the Wenner Four-Pin Method in accordance with ASTM G57. In cases of parallel pipes or in areas of intersecting pipelines, it may be necessary to use the Single-Pin Method to accurately measure the soil resistivity. For measuring resistivity of soil samples from auger holes or excavations, a soil box serves as a convenient means for obtaining accurate results.

The depth of the piping shall be considered in selecting the method to be used and the location of samples. The testing and evaluation of results should be performed by personnel trained and experienced in soil resistivity testing.

9.6 Cathodic Protection Monitoring

Cathodically protected buried process piping shall be monitored regularly to assure adequate levels of protection. Monitoring shall include periodic measurement and analysis of pipe-to-soil potentials by personnel trained and experienced in cathodic protection system operation. More frequent monitoring of critical cathodic protection components, such as impressed current rectifiers, may be needed to ensure reliable system operation. Owner/users should keep appropriate records of CP monitoring and maintenance performed as a result of CP system monitoring.

Refer to NACE SP0169 and Section 11 of API 651 for guidance applicable to inspecting and maintaining cathodic protection systems for buried piping.

9.7 Inspection Methods

A number of direct examination techniques methods are available that may be applied to buried piping and a more extensive guide to these can be found in API RP 574. Some methods can indicate the external or wall condition of the piping, whereas other methods indicate only the internal condition. Additionally some methods are able to simultaneously detect and quantify both wall loss and deformation damage such as denting, ovality, bulging, swelling, etc.

An array of technologies are now available that can be externally applied to buried piping at a location and screen select areas from that position. These techniques may require some excavation but considerable less than a full access described earlier. An example of these techniques is guided wave examination, previously known as long range ultrasonics (LRUT) or guided wave ultrasonic testing (GWUT). These technologies may allow 15 ft or longer distances to be screened from one installation and provide a screening assessment of the pipe. Distance travelled and the degree of detection/accuracy is a function of the applied technology and pipe conditions including degree of corrosion, external and internal coatings and soil conditions, transported product and type and number of accessories in the path of the signal.

Other technologies employing ultrasound may be used to screen several feet from one location and are useful for assessing damage in locations such as soil-to-air interfaces. Reference API 574 for examples of other technologies.

9.8 Frequency and Extent of Inspection

9.8.1 Above-grade Visual Surveillance

The owner/user should, at approximately six month intervals survey the surface conditions on and adjacent to each buried piping path (see 9.2).

9.8.2 Pipe-to-soil Potential Survey

A close-interval potential survey on a cathodically protected line may be used to verify that the buried piping has a protective potential throughout its length. For poorly coated pipes where cathodic protection potentials are

inconsistent, the survey may be conducted at three- to five-year intervals for verification of continuous corrosion control.

For piping with no cathodic protection or in areas where leaks have occurred due to external corrosion, a pipe-to-soil potential survey may be conducted along the pipe route. The pipe should be excavated for inspection or inspected with appropriate NDE at sites where possibilities of active corrosion cells have been located to determine the extent of corrosion damage. A continuous potential profile or a close-interval survey may be required to better locate active corrosion cells.

9.8.3 Pipe Coating Holiday Survey

The frequency of pipe coating holiday surveys is usually based on indications that other forms of corrosion control are ineffective. For example, on a coated pipe where there is gradual loss of cathodic protection potentials or an external corrosion leak occurs at a coating defect, a pipe coating holiday survey may be used to evaluate the coating.

9.8.4 Soil Corrosivity

For piping buried in lengths greater than 100 ft (30 m) and not cathodically protected, evaluations of soil corrosivity should be performed at appropriate intervals based on likelihood of change. Soil resistivity measurements may be used for relative classification of the soil corrosivity (see 9.5). Additional factors that may warrant consideration are changes in soil chemistry and analyses of the polarization resistance of the soil and piping interface.

9.8.5 External and Internal Inspection Intervals

If internal corrosion of buried piping is expected as a result of inspection on the above-grade portion of the line, inspection intervals and methods for the buried portion should be adjusted accordingly. The inspector should be aware of and consider the possibility of accelerated internal corrosion in deadlegs.

The external condition of buried piping that is not cathodically protected should be determined by either pigging, which can measure wall thickness, or by excavating according to the frequency given in Table 4. Significant external corrosion detected by pigging or by other means may require excavation and evaluation even if the piping is cathodically protected.

Piping inspected periodically by excavation shall be inspected in lengths of 6 ft to 8 ft (2.0 m to 2.5 m) at one or more locations judged to be most susceptible to corrosion. Excavated piping should be inspected full circumference for the type and extent of corrosion (pitting or general) and the condition of the coating.

If inspection reveals damaged coating or corroded piping, additional piping shall be excavated until the extent of the condition is identified. If the average wall thickness is at or below the minimum required thickness, it shall be repaired or replaced.

If the piping is contained inside a casing pipe, the condition of the casing should be inspected to determine if water and/or soil has entered the casing. The inspector should verify the following:

- a) both ends of the casing extend beyond the soil surface,
- b) the ends of the casing are sealed if the casing is not self-draining,
- c) the pressure-carrying pipe is properly coated and wrapped, and
- d) there is no metallic or electrolytic contact between the casing and the pressure carrying pipe.

9.8.6 Leak Testing Intervals

An alternative or supplement to inspection is leak testing with liquid at a pressure at least 10 % greater than maximum operating pressure at intervals one-half the length of those shown in Table 4 for piping not cathodically protected and at the same intervals as shown in Table 4 for cathodically protected piping. The leak test should be maintained for a period of eight (8) hours. Four hours after the initial pressurization of the piping system, the pressure should be noted and, if necessary, the line repressurized to original test pressure and isolated from the pressure source. If, during the remainder of the test period, the pressure decreases more than 5 %, the piping should be visually inspected externally and/or inspected internally to find the leak and assess the extent of corrosion. Sonic measurements may be helpful in locating leaks during leak testing.

Buried piping also may be surveyed for integrity by using temperature-corrected volumetric or pressure test methods. Other alternative leak test methods involve acoustic emission examination and the addition of a tracer fluid to the pressurized line (such as helium or sulfur hexafluoride). If the tracer is added to the service fluid, the owner/user shall confirm suitability for process and product.

Table 4—Frequency of Inspection for Buried Piping Without Effective Cathodic Protection

Soil Resistivity (ohm-cm)	Inspection Interval (years)
<2,000	5
2000 to 10,000	10
>10,000	15

9.9 Repairs to Buried Piping Systems

9.9.1 Repairs to Coatings

Any coating removed for inspection shall be renewed and inspected appropriately. For coating repairs, the inspector should be assured that the coating meets the following criteria:

- a) it has sufficient adhesion to the pipe to prevent under-film migration of moisture,
- b) it is sufficiently ductile to resist cracking,
- c) it is free of voids and gaps in the coating (holidays),
- d) it has sufficient strength to resist damage due to handling and soil stress,
- e) it can support any supplemental cathodic protection.

In addition, coating repairs may be tested using a high voltage holiday detector. The detector voltage shall be adjusted to the appropriate value for the coating material and thickness. Any holidays found shall be repaired and retested.

9.9.2 Clamp Repairs

In general, bolted clamps should be avoided for temporary repairs to all buried piping. If piping leaks are clamped and reburied, the location of the clamp shall be logged in the inspection record and may be surface marked. Both the marker and the record shall note the date of installation and the location of the clamp. All clamps shall be considered temporary. Temporary repairs on buried piping should be permanently repaired at the next maintenance opportunity unless approved for extension by a piping engineer.

9.9.3 Welded Repairs

Welded repairs shall be made in accordance in 8.2.

9.10 Records

Record systems for buried piping should be maintained in accordance with 7.9. In addition, a record of the location and date of installation of temporary clamps shall be maintained. Also, buried piping should be located on a drawing (i.e. plot plan or piping iso) indicating size and external corrosion mitigation.

Annex A (informative)

Inspector Certification

A.1 Examination

An examination to certify inspectors within the scope of API 570 shall be based on the current API 570 inspector certification body of knowledge as published by API.

A.2 Certification

An API 570 authorized piping inspector certification will be issued when an applicant has successfully passed the API 570 certification exam and satisfies the criteria for experience and education. Education and experience, when combined, shall be equal to at least one of the following:

- a) a Bachelor of Science degree in engineering or technology, plus one year of experience in supervision of inspection activities or performance of inspection activities as described in API 570;
- b) a two-year degree or certificate in engineering or technology, plus two years of experience in the design, construction, repair, inspection, or operation of piping systems, of which one year must be in supervision of inspection activities or performance of inspection activities as described in API 570;
- c) a high school diploma or equivalent, plus three years of experience in the design, construction, repair, inspection, or operation of piping systems, of which one year must be in supervision of inspection activities or performance of inspection activities as described in API 570;
- d) a minimum of five years of experience in the design, construction, repair, inspection, or operation of piping systems, of which one year must be in supervision of inspection activities or performance of inspection activities as described in API 570.

A.3 Recertification

A.3.1 Recertification is required three years from the date of issuance of the API 570 authorized piping inspector certificate. Recertification by examination will be required for authorized piping inspectors who have not been actively engaged as authorized piping inspectors within the most recent three-year certification period and for authorized piping inspectors who have not previously passed the exam. Exams will be in accordance with all provisions contained in API 570.

A.3.2 “Actively engaged as an authorized piping inspector” shall be defined as a minimum of 20 % of time spent performing inspection activities or supervision of inspection activities, or engineering support of inspection activities, as described in the API 570, over the most recent three year certification period.

Note: Inspection activities common to other API inspection documents (NDE, record-keeping, review, of welding documents, etc.) may be considered here.

A.3.3 Once every other recertification period (every six years), inspectors actively engaged as an authorized piping inspector shall demonstrate knowledge of revisions to API 570 that were instituted during the previous six years. This requirement shall be effective six years from the inspector's initial certification date. Inspectors who have not been actively engaged as an authorized piping inspector within the most recent three-year certification period shall recertify as required in A.3.1.

Annex B (informative)

Requests for Interpretations

B.1 Introduction

API will consider written requests for interpretations of API 570. API staff will make such interpretations in writing after consultation, if necessary, with the appropriate committee officers and the committee membership. The API committee responsible for maintaining API 570 meets regularly to consider written requests for interpretations and revisions, and to develop new criteria as dictated by technological development. The committee's activities in this regard are limited strictly to interpretations of the latest edition of API 570 or to the consideration of revisions to API 570 based on the new data or technology.

As a matter of policy, API does not approve, certify, rate, or endorse any item, construction, proprietary device, or activity; and accordingly, inquiries requiring such consideration will be returned. Moreover, API does not act as a consultant on specific engineering problems or on the general understanding or application of the rules. If, based on the inquiry information submitted, it is the opinion of the committee that the inquirer should seek engineering or technical assistance, the inquiry will be returned with the recommendation that such assistance be obtained.

All inquiries that do not provide the information needed for full understanding will be returned.

B.2 Inquiry Format

Inquiries shall be limited strictly to requests for interpretation of the latest edition of API 570 or to the consideration of revisions to API 570 based on new data or technology. Inquiries shall be submitted in the following format.

- a) Scope—The inquiry shall involve a single subject or closely related subjects. An inquiry letter concerning unrelated subjects will be returned.
- b) Background—The inquiry letter shall state the purpose of the inquiry, which shall be either to obtain an interpretation of API 570 or to propose consideration of a revision to API 570. The letter shall provide concisely the information needed for complete understanding of the inquiry (with sketches, as necessary) and include references to the applicable edition, revision, paragraphs, figures, and tables.
- c) Inquiry—The inquiry shall be stated in a condensed and precise question format, omitting superfluous background information and, where appropriate, composed in such a way that “yes” or “no” (perhaps with provisos) would be a suitable reply. This inquiry statement should be technically and editorially correct. The inquirer shall state what he or she believes API 570 requires. If in the opinion of the inquirer a revision to API 570 is needed, the inquirer shall provide recommended wording.

Submit the request for interpretation to the API Request for Interpretation website at: <http://apiti.api.org>.

B.3 Request for Interpretation Responses

Responses to previous request for interpretation can be found on the API website at <http://mycommittees.api.org/standards/reqint/default.aspx>.

Annex C (informative)

Examples of Repairs

C.1 Repairs

ASME PCC-2, Repair of Pressure Equipment and Piping provides guidance on various types of repairs, such as: butt welded insert plates, external weld overlay to repair internal thinning, Full Encirclement Steel Reinforcing Sleeves for Piping, Weld Buildup, Weld Overlay, and Clad Restoration or Fillet Welded Patches

Manual welding utilizing the gas metal-arc or shielded metal-arc processes may be used.

When the temperature is below 50 °F (10 °C), low-hydrogen electrodes, AWS E-XX16 or E-XX18, shall be used when welding materials conforming to ASTM A-53, Grades A and B; A-106, Grades A and B; A-333; A-334; API 5L; and other similar material. These electrodes should also be used on lower grades of material when the temperature of the material is below 32 °F (0 °C). The piping engineer should be consulted for cases involving different materials.

When AWS E-XX16 or E-XX18 electrodes are used on weld numbers 2 and 3 (see Figure C.1 below), the beads shall be deposited by starting at the bottom of the assembly and welding upward. The diameter of these electrodes should not exceed $\frac{5}{32}$ in. (4.0 mm). Electrodes larger than $\frac{5}{32}$ in. (4.0 mm) may be used on weld number 1 (see Figure C.1), but the diameter should not exceed $\frac{3}{16}$ in. (4.8 mm).

The longitudinal welds (number 1, Figure C.1) on the reinforcing sleeve shall be fitted with a suitable tape or mild steel backing strip (see note) to avoid fusing the weld to the side wall of the pipe.

NOTE If the original pipe along weld number 1 has been checked thoroughly by ultrasonic methods and it is of sufficient thickness for welding, a backing strip is not necessary.

All repair and welding procedures for on-stream lines shall conform to API 2201.

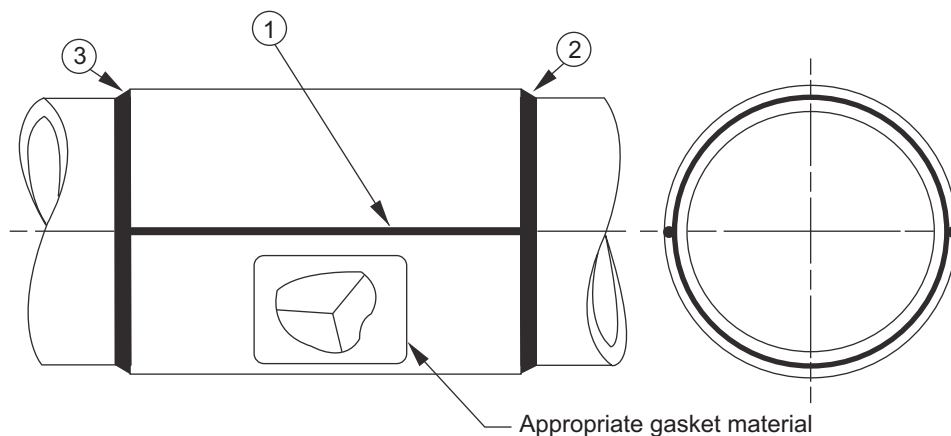

Figure C.1—Encirclement Repair Sleeve

C.2 Small Repair Patches

The diameter of electrodes should not exceed $\frac{5}{32}$ in. (4.0 mm). When the temperature of the base material is below 32 °F (0 °C), low-hydrogen electrodes shall be used. Weaving of weld beads deposited with low-hydrogen electrodes should be avoided.

All repair and welding procedures for on-stream lines shall conform to API 2201.

Examples of small repair patches are shown below in Figure C.2.

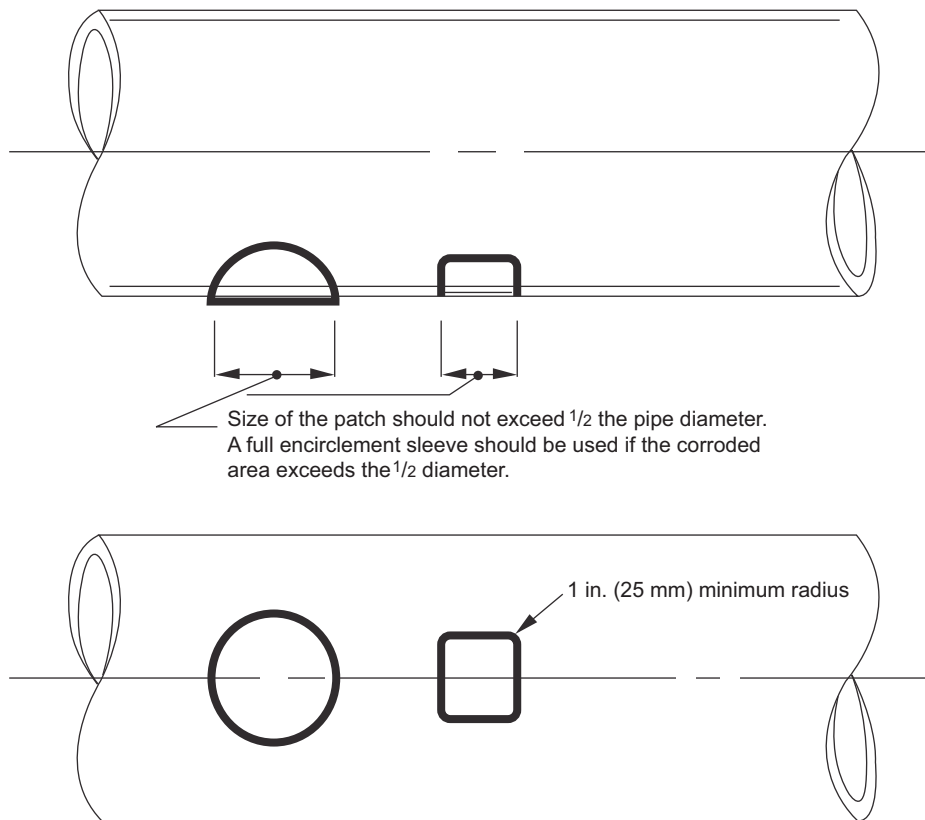

Figure C.2—Small Repair Patches

Annex D (informative)

Two Examples of the Calculation of MAWP Illustrating the Use of the Corrosion Half-life Concept

Example 1	
Design pressure/temperature	500 psig/400 °F (3447 kPa/204 °C)
Pipe description	NPS 16, standard weight, A 106-B
Outside diameter of pipe, D	16 in. (406 mm)
Allowable stress	20,000 psi (137,900 kPa)
Longitudinal weld efficiency, E	1.0
Thickness determined from inspection	0.32 in. (8.13 mm)
Observed corrosion rate (see 7.1)	0.01 in./year (0.254 mm/year)
Next planned inspection	5 years
Estimated corrosion loss by date of next inspection	$= 5 \times 0.01 = 0.05$ in. ($5 \times 0.254 = 1.27$ mm)
Estimated thickness minus twice the estimated corrosion loss, t	$= (0.32 - (0.05 \times 2)) = 0.22$ in. [$=(8.13 - (1.27 \times 2)) = 5.59$ mm]
MAWP In U.S. Customary (USC) units	$= 2SEt/D = 550$ psig
In SI units	$= 3747$ kPa
Conclusion: OK	
Example 2	
Next planned inspection	7 years
Estimated corrosion loss by date of next inspection	$= 7 \times 0.01 = 0.07$ in. ($7 \times 0.254 = 1.78$ mm)
Estimated thickness minus twice the estimated corrosion loss, t	$= (0.32 - (0.07 \times 2)) = 0.18$ in. [$=(8.13 - (1.78 \times 2)) = 4.57$ mm]
MAWP In USC units	$= 2SEt/D = 450$ psig
In SI units	$= 3104$ kPa
Conclusion: Must reduce inspection interval or determine that normal operating pressure will not exceed this new MAWP during the seventh year, or renew the piping before the seventh year.	
NOTE 1 psig = pounds per square inch gauge; psi = pounds per square inch.	
NOTE 2 The formula for MAWP is from ASME B31.3, Equation 3b, where t = corroded thickness.	

Bibliography

- [1] API Recommended Practice 581, *Risk-based Inspection Methodology*
- [2] API Recommended Practice 751, *Safe Operation of Hydrofluoric Acid Alkylation Units*
- [3] API Recommended Practice 585, *Pressure Equipment Integrity Incident Investigations*
- [4] API Recommended Practice 651, *Cathodic Protection of Aboveground Petroleum Storage Tanks*
- [5] ASNT SNT-TC-1 ⁵, *A Personnel Qualification and Certification in Nondestructive Testing*
- [6] ASNT CP-189, *Standard for Qualification and Certification of Nondestructive Testing Personnel*
- [7] MTI 129 ⁶, *A Practical Guide to Field Inspection of FRP Equipment and Piping*
- [8] NACE SP 0169 ⁷, *Control of External Corrosion on Underground or Submerged Metallic Piping Systems*
- [9] NACE RP 0170, *Protection of Austenitic Stainless Steels and Other Austenitic Alloys from Polythionic Acid Stress Corrosion Cracking During Shutdown of Refinery Equipment*
- [10] NACE SP 0114, *Refinery Injection and Process Mixing Points*
- [11] AWS QC1, *Standard for AWS Certification of Welding Inspectors*

⁵American Society for Nondestructive Testing, P.O. Box 28518, 1711 Arlingate Lane, Columbus, Ohio 43228-0518, www.asnt.org

⁶Materials Technology Institute, Inc., 1215 Fern Ridge Parkway, Suite 206, St. Louis, Missouri 63141, www.mtiproducts.org

⁷NACE International (formerly the National Association of Corrosion Engineers), 1440 South Creek Drive, Houston, Texas 77218-8340, www.nace.org



AMERICAN PETROLEUM INSTITUTE

1220 L Street, NW
Washington, DC 20005-4070
USA

202-682-8000

Additional copies are available online at www.api.org/pubs

Phone Orders: 1-800-854-7179 (Toll-free in the U.S. and Canada)
303-397-7956 (Local and International)
Fax Orders: 303-397-2740

Information about API publications, programs and services is available
on the web at www.api.org.

Product No. C57004